



RUSSIAN FEDERATION  
MINISTRY OF TRANSPORT OF THE RUSSIAN FEDERATION  
FEDERAL AIR TRANSPORT AGENCY

**AIRWORTHINESS DIRECTIVE**

7 December 2017

№ 2017-322-05

**Applicability –RRJ-95 Aircraft**

**State of Manufacture – Russian Federation**

---

The corrective actions prescribed by this Airworthiness Directive are mandatory. No persons may operate an aircraft to which this Airworthiness Directive applies, except in accordance with the requirements of this Airworthiness Directive.

---

Due to the fact of cracks discovered on Frame 58 Web in Section F5 Lower part, in the area of the flanges for attachment of the Longitudinal Rods, during RRJ-95 A/C operation *the following propose is made:*

1. On the next weekly maintenance check the RRJ-95 aircraft Operators with the SCAC representative assistance to perform a detailed inspection of the Frame 58 in Section F5 Lower part between 23-24 stringers and between 33-34 stringers, in the area of the flanges for attachment of the Longitudinal Rods, in accordance with the AMM task 53-86-00-220-803 and the Technical decision № RRJ0000-OR-470-0975.

2. If during inspection any cracks on Frame 58 Web are detected, to ensure implementation of repair activities in accordance with the Decision № RRJ0000-OR-470-1062 issued by SCAC. To perform inspection of the A/C after the repair with the interval 50 FC before the 3 months/1000 FH/500 FC in accordance with the AMM task 53-86-00-220-803. The decision on an extension of this period is accepted by SCAC.

3. If, during any inspection as required by paragraph (1) of this Airworthiness Directive, no findings are detected, the inspection to be performed each 100 FC until the effective date of the revision AMM ALS (Section 04).

4. It is necessary to issue a Service Bulletin for the retrofit of Frame 58 Web.

Attachments: Technical decision № RRJ0000-OR-470-0975, 1 page, 1 copy.

Decision № RRJ0000-OR-470-1062, 24 pages, 1 copy.

---

**Deputy General Director**

**M. Bulanov**

---

**«APPROVED»**  
Chief Designer for SSJ Program



«08 / 11»  
V. Lavrov  
2017

**TECHNICAL DECISION № RRJ0000-OR-470-0975**  
for RRJ-95 A/C continued airworthiness due to the fact of the cracks  
discovered on Frame 58 Web

Due to the fact of cracks discovered on Frame 58 Web in Section F5 Lower part, in the area of the flanges for attachment of the Longitudinal Rods, during A/C operation the following decision is made:

1. On the next weekly maintenance check the RRJ-95 aircraft Operators with the SCAC representative assistance to perform a detailed inspection of the Frame 58 in Section F5 Lower part between 23-24 stringers and between 33-34 stringers, in the area of the flanges for attachment of the Longitudinal Rods, in accordance with the AMM task 53-86-00-220-803.

The results of the inspection shall be sent to SCAC Customer Support Center to [customercare@scac.ru](mailto:customercare@scac.ru) and [airworthiness@scac.ru](mailto:airworthiness@scac.ru).

2. If, during any inspection as required by paragraph (1) of this Decision, no findings are detected, to continue the A/C operation with the inspection to be performed each 100 FC according to the paragraph (1) of this Decision.

The results of the inspection shall be sent to SCAC Customer Support Center to [customercare@scac.ru](mailto:customercare@scac.ru) and [airworthiness@scac.ru](mailto:airworthiness@scac.ru).

3. If, during any inspection as required by paragraphs (1) and (2) of this Decision, any cracks on Frame 58 Web are detected, to perform the SCAC Customer Support Center recommendations based on the provided inspections results by Operators.

4. Based on the results of resource analysis to include to the Airworthiness Limitations Section (AMM Chapter 04) next revision and put in force the requirement concerning the Frame 58 web in Section F5 Lower part, in the area of the flanges for attachment of the Longitudinal Rods, additional inspections performance.

Due date: 15.04.2018.

5. It is necessary to prepare and issue a Service Bulletin №RRJ-53-00408-БД and Repair Approval Sheet № 050-2017 (EASA Environment) for the retrofit of Frame 58 Web in Section F5 Lower part, in the area of the flanges for attachment of the Longitudinal Rods.

Due date: 29.12.2017.

**RRJ0000-OR-470-0975**

«APPROVED»

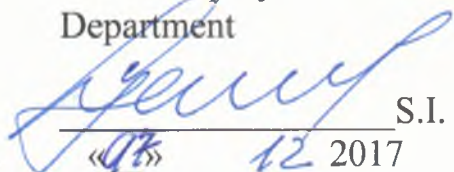
FATA Deputy Head of Airworthiness  
Department

S.I. Suslov

«24» 12 2017

«APPROVED»

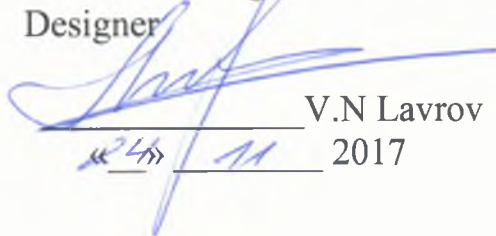
SCAC SSJ Program Chief  
Designer

V.N. Lavrov

«24» 11 2017

**DECISION NO. RRJ0000-OR-470-1062**

on RRJ-95 aircraft repair in Frame 58 Web

Due to detection of the damages (cracks) on Frame 58 Web in the Lower F6 Section, between STR23-STR24 and STR33-STR34 the aft service compartment, due to inspections in accordance with the task AMM 53-86-00-220-803 «Detailed Inspection of Frame 58 including the Stabilizer Hinge Fittings» the following decision is taken:

**DECISION:**

1. To perform repair work on Frame 58 Web according to the following procedure:
  - 1.1. Removal of the APU according to AMM 49-11-01-000-801.
  - 1.2. Disconnect the electrical connector and the bonding straps on the firewall of frame 58 from the F5 Section. Remove and save the clamps and tie-down fitting.

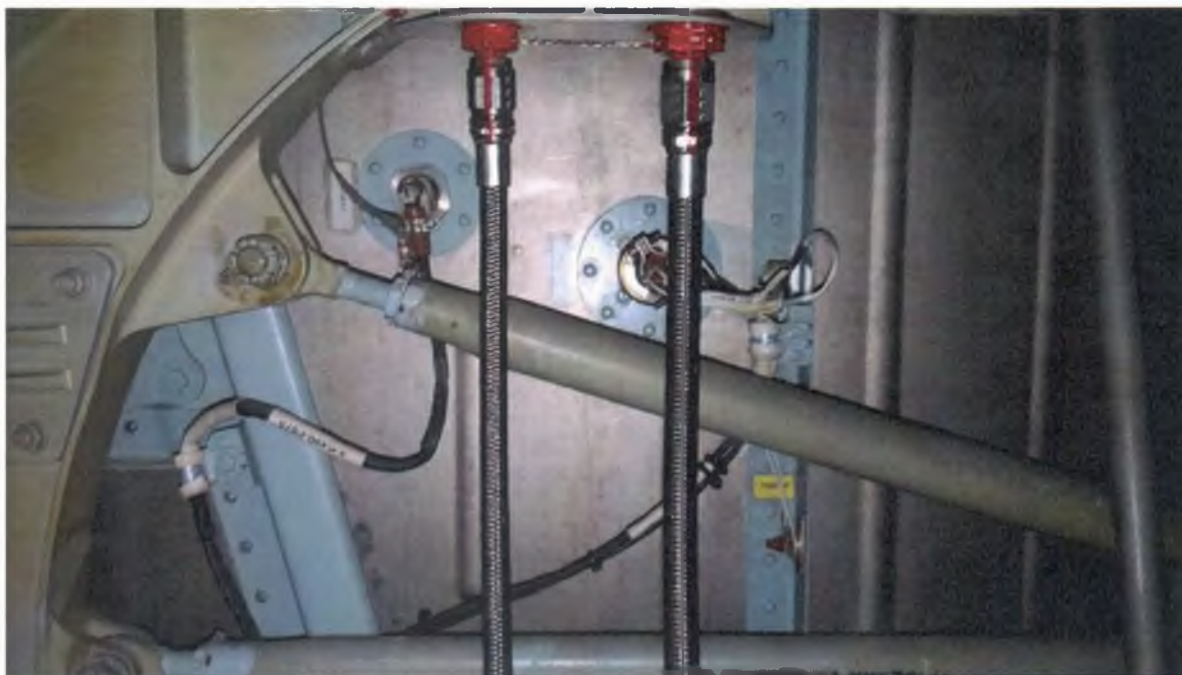

Figure 1. Connectors 3-K490-P675, 5-F5/F6-P1-A





Figure 2. Ground point 1143-GP.



Figure 3. Connectors TCES-20-62C, 1-F5/F6-X-A, 2-F5/F6-X-A, 3-F5/F6-P-A, 4-F5/F6-LN-A, 6-Q280-X1.



Figure 4. Ground point 1140-GP, 1139-GP, 382-GP.



Figure 5. Connector 1-K490-P677

- 1.3. Remove the clamps. Save the clamps and tie-down fitting.





Figure 6. Clamps.



Figure 7. Clamps.

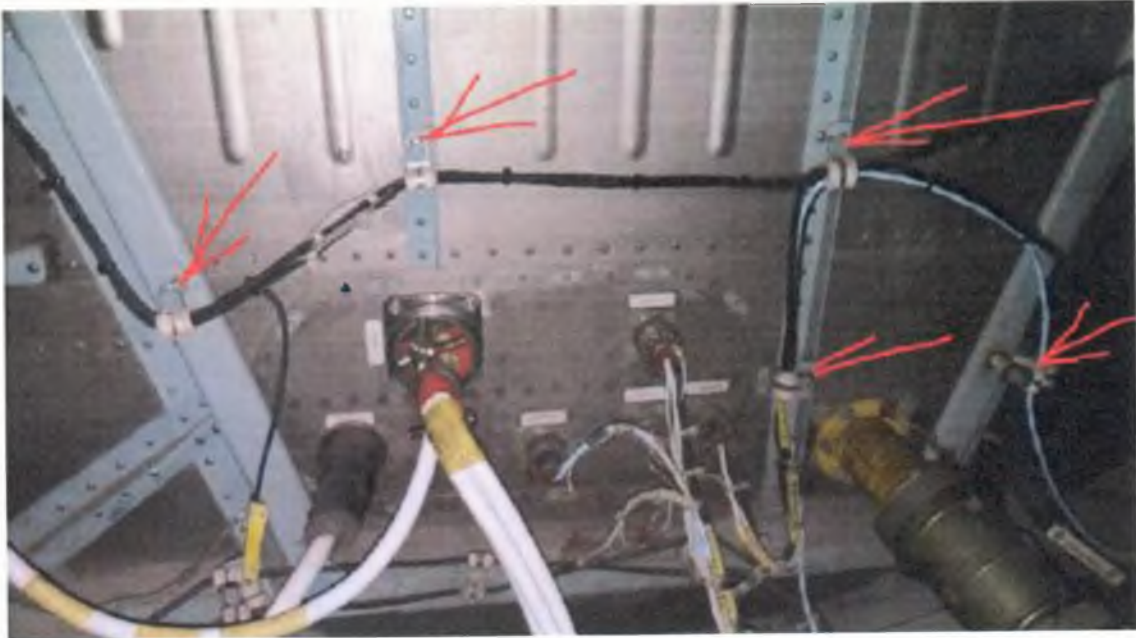

Figure 8. Clamps.

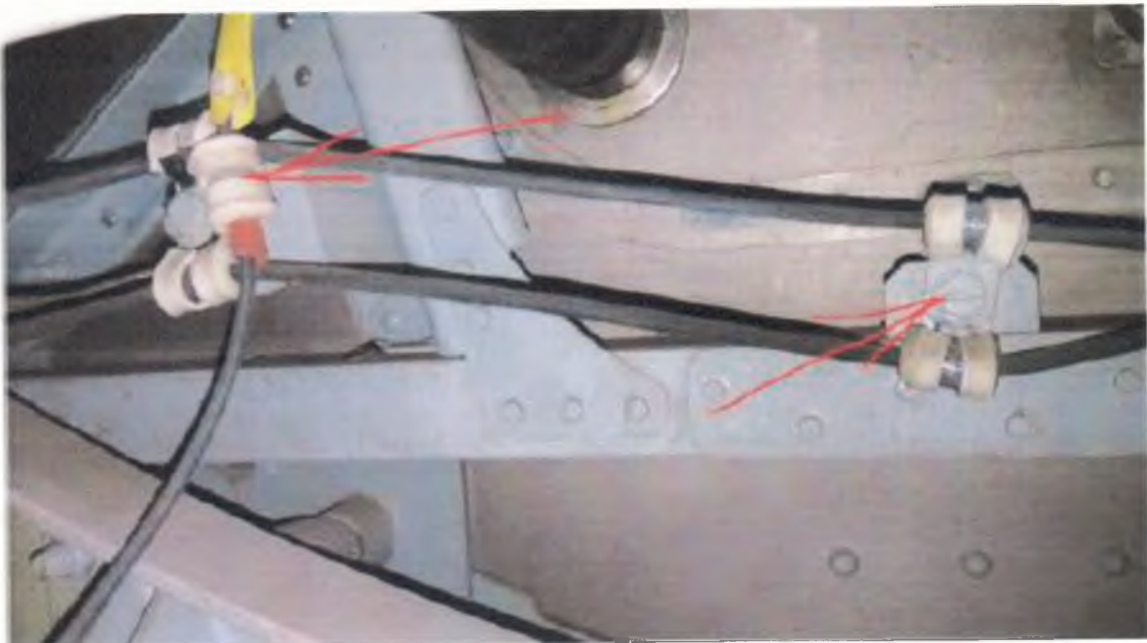

Figure 9. Clamps.



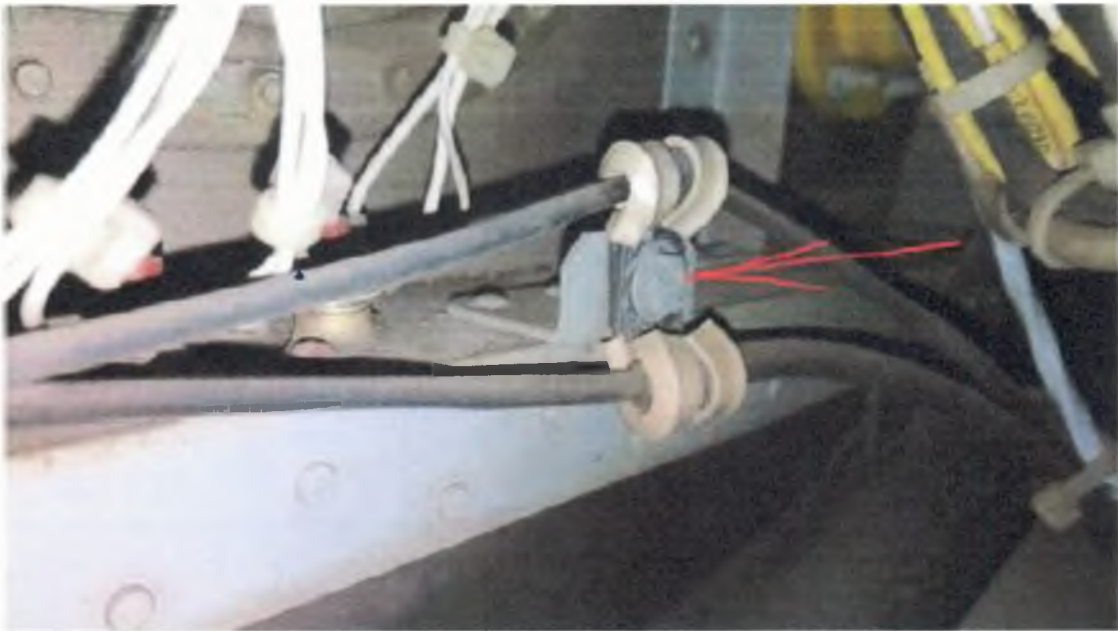

Figure 10. Clamps.



Figure 11. Clamps.



- 1.4. Disconnect the fuel pipeline P/N T7.92.6167.009.000.73 from the F6 Section. It should be possible during the removal of Section F6 to do not damage the last portion T7.92.6167.060.000.70 on the firewall of frame 58a from the F6 Section.



The last portion  
T7.92.6167.060.000.70

The last portion  
T7.92.6167.060.000.70

Figure 12. Fuel pipeline.

- 1.5. Carefully remove the heat insulation proofing from the air bleed duct, remove the clamp and disconnect pipe line. Save the clamps, gasket and tie-down fitting.



Figure 13. Air bleed duct.

- 1.6. Disconnect pipe fire extinguisher system from the firewall of frame 58a the F5 Section.

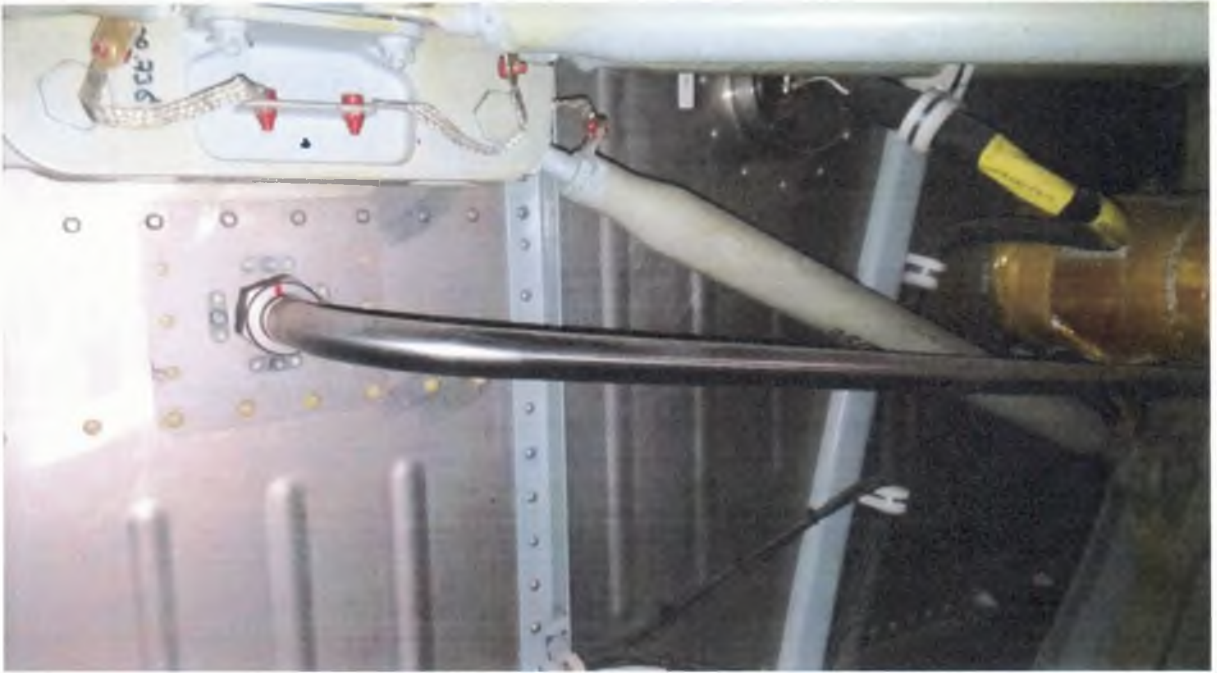

Figure 14. Fire extinguisher system.

- 1.7. Disconnect bonding terminal from the firewall of the F5 Section. Save the tie-down fitting.



Figure 15. Ground point 1111-GP.



- 1.8. Remove the bonding straps between frame 58a the F5 Section and F6 Section.



Figure 16. The bonding straps.

- 1.9. Remove the Elevator according to AMM 55-20-00-900-801.

- 1.10. Remove:

- Left upper panel P/N T7.92.3125.175.003.73;
- Left lower panel P/N T7.92.3125.175.005.73;
- Left diaphragm P/N T7.92.3125.175.007.73;
- Right upper panel P/N T7.92.3125.175.004.73;
- Right lower panel P/N T7.92.3125.175.006.73;
- Right diaphragm P/N T7.92.3125.175.008.73.

Save the tie-down fitting.

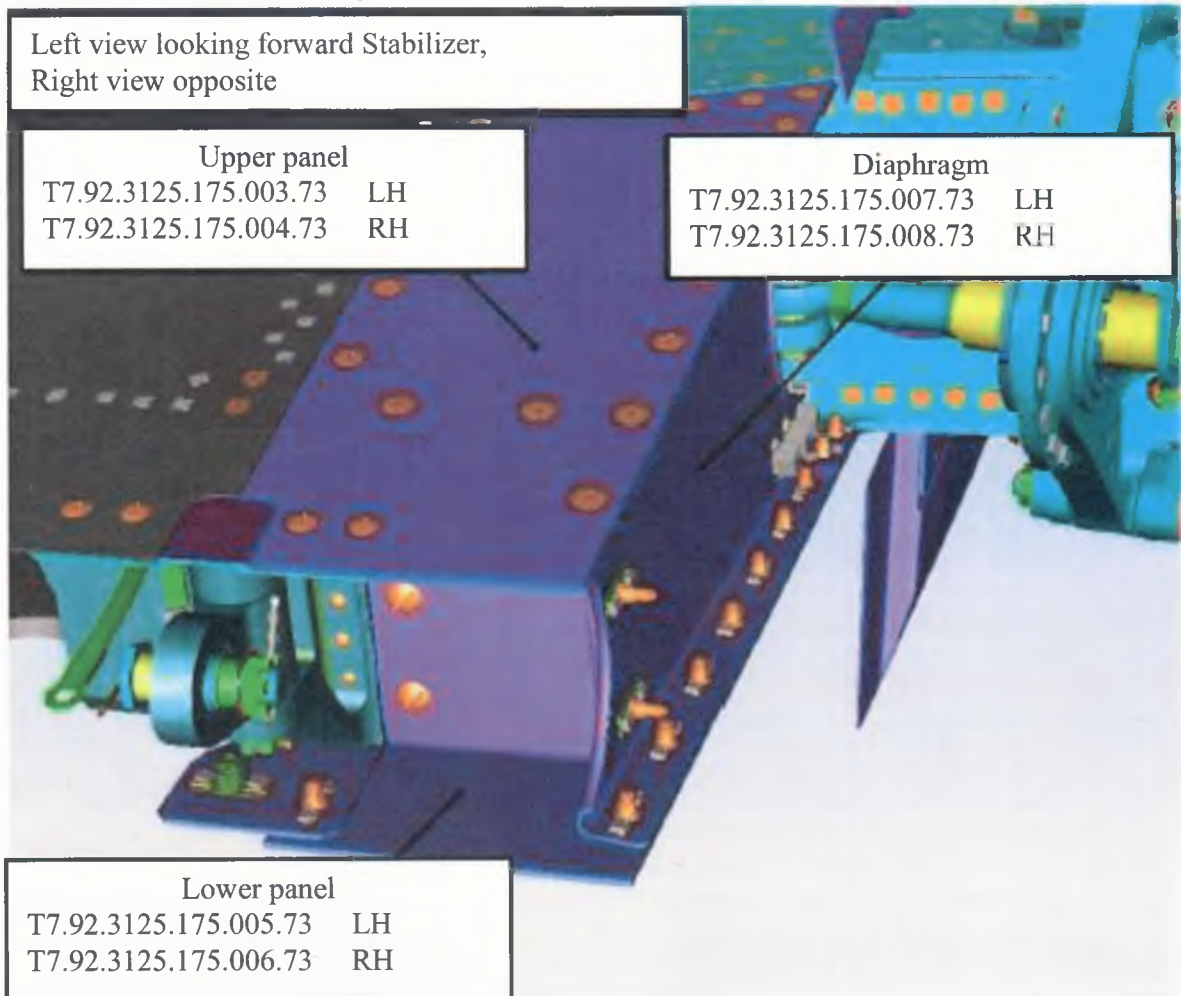

Figure 17. Removal panels and diaphragms.



- 1.11. Remove the left access door P/N T7.92.0861.100.000.70 and upper panel P/N T7.92.0845.100.000.70, screws P/Ns: 5-12-Ц-OCT 1 31538-80 - 24 qty. and 5-14 - Ц-OCT 1 31538-80 – 2 qty.

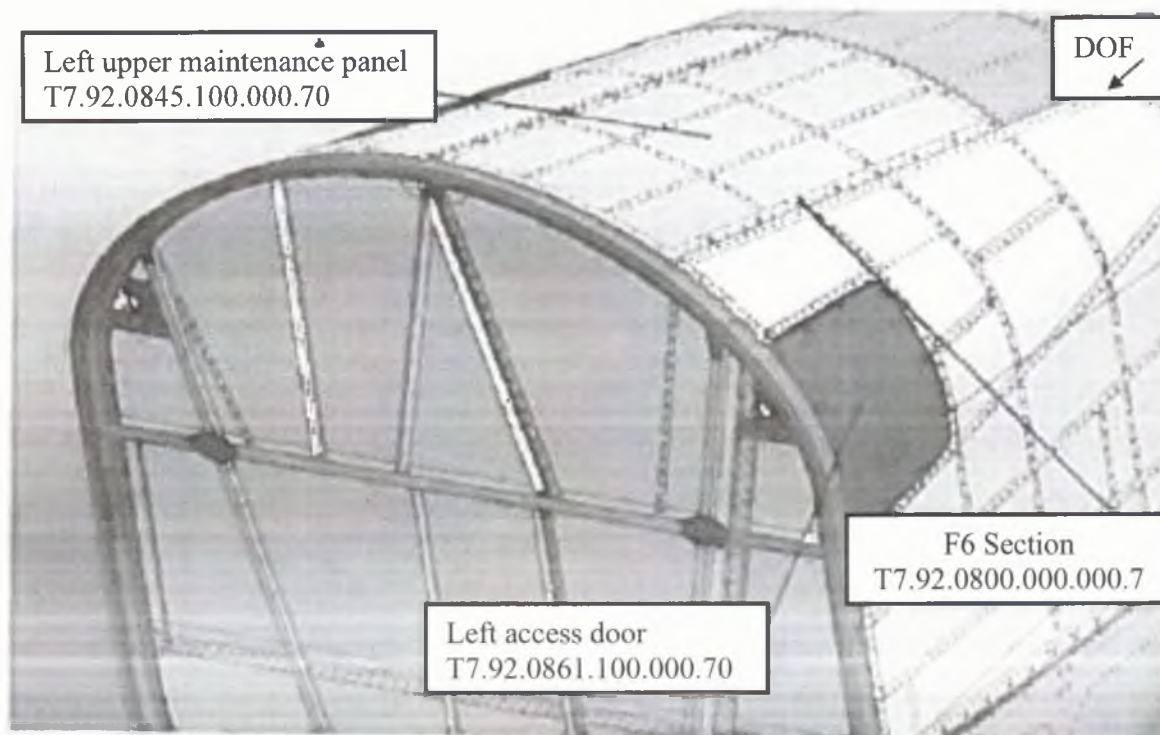

Figure 18. Access door.

- 1.12. To install a lifting tool. (See Attachment 1).

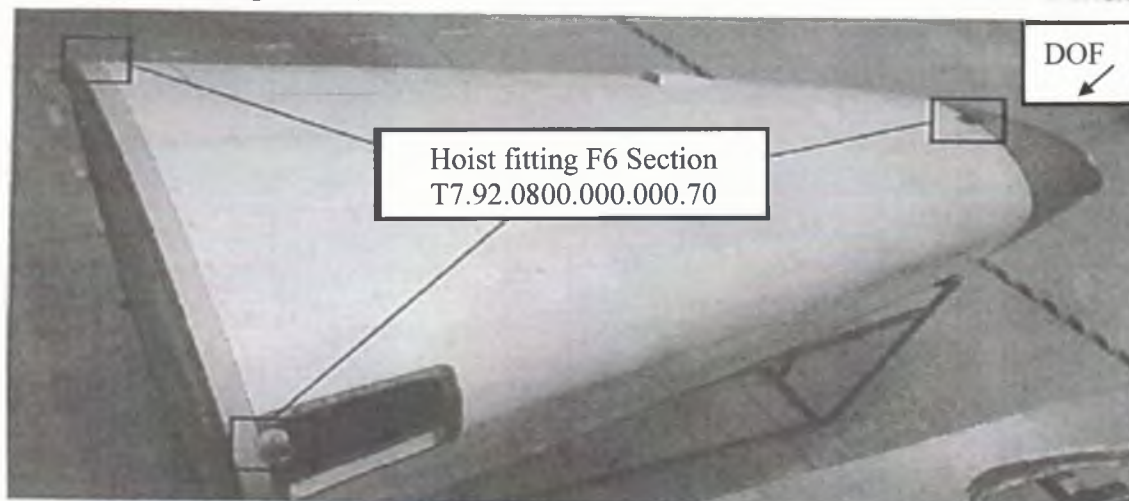

Figure 19. Hoist fitting F6 Section

### 1.13. Preparation for Removal F6 Section:

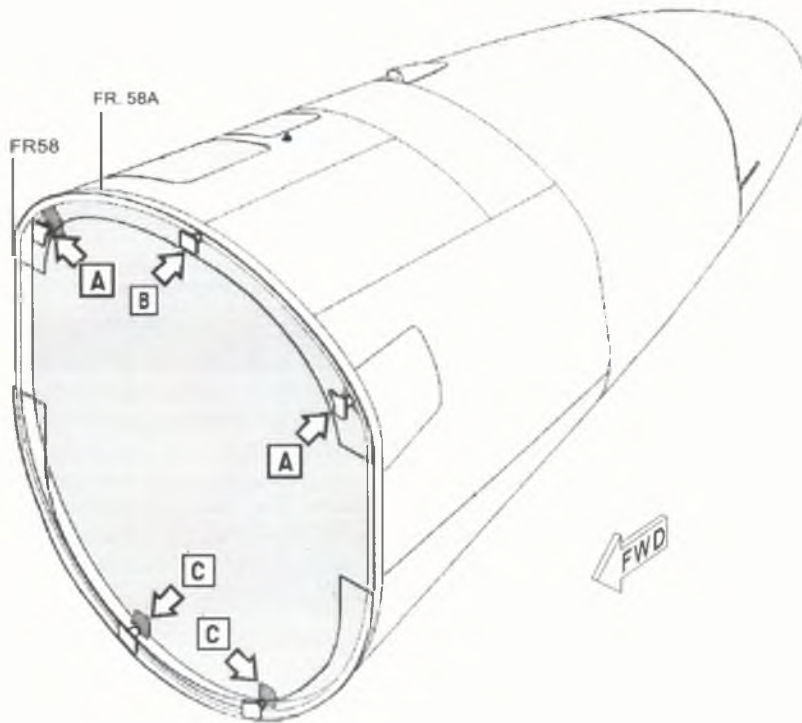

Figure 20. Hoist fitting F6 Section

- 1.14. Remove the cotter pins, nuts and washers for each fitting.  
**NOTES.** Access from F6 Section. Save nuts and washers.

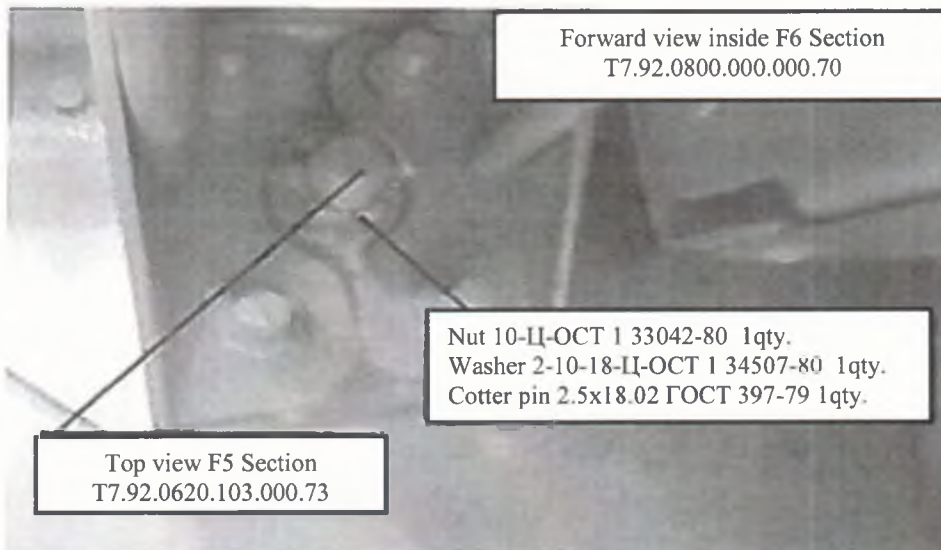

Figure 21. Upper fitting.

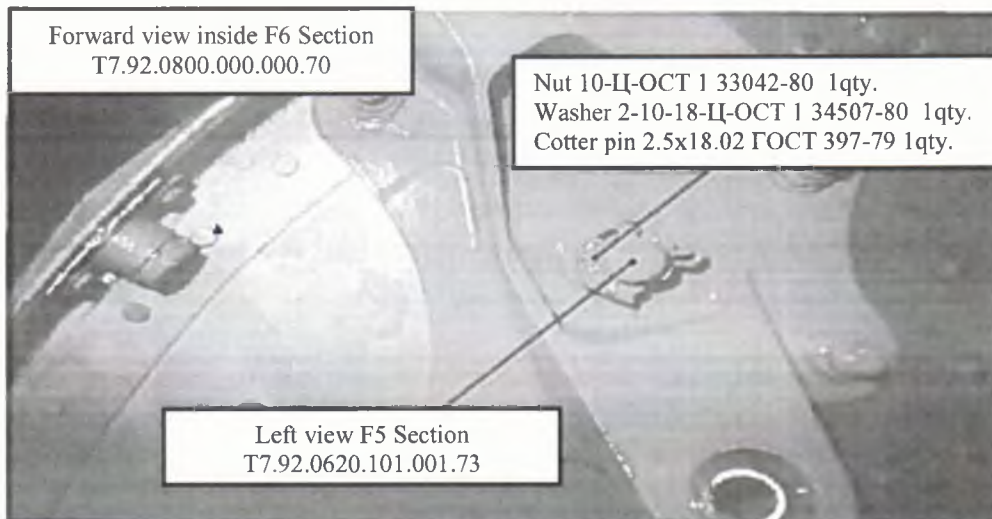

Figure 22. Left upper fitting

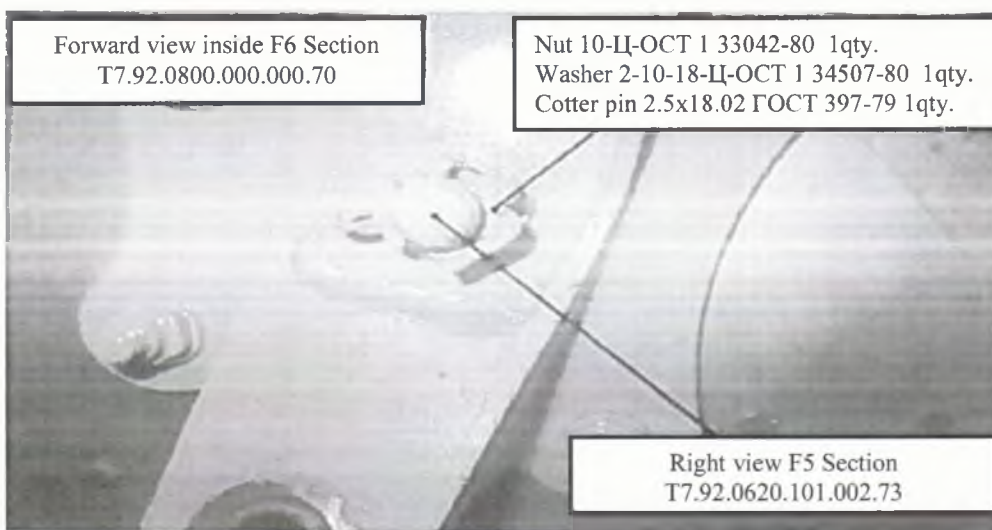

Figure 23. Right upper fitting

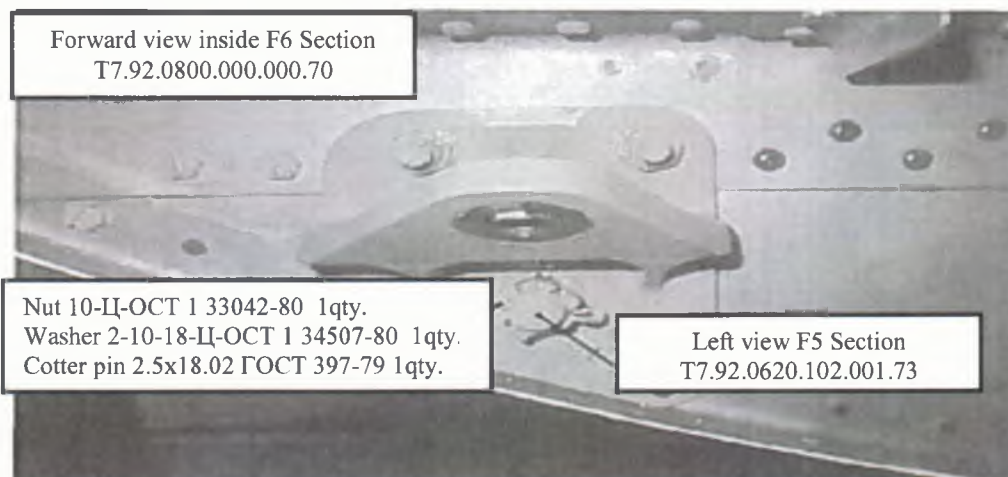

Figure 24. Left lower fitting.



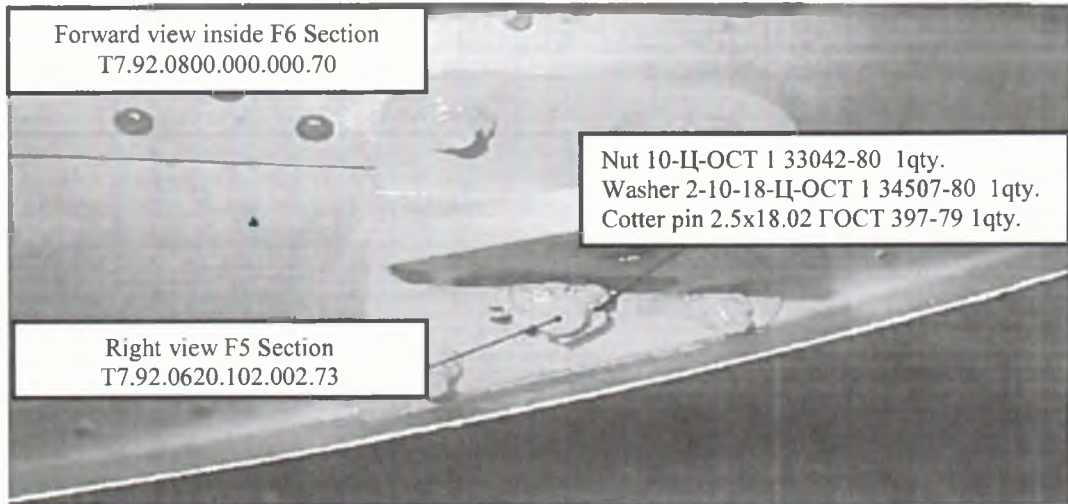

Figure 25. Right lower fitting.

- 1.15. Move Section F6 from Section F5.
- 1.16. Move Section F6 smoothly from Section F5 without tension and damages hinge fixing.
- 1.17. To fix Section F6 on the cradle or on the soft blanket in order to prevent them deformation and damages.

**NOTES:** In the absence of a soft blanket or tool holders, may be stored in suspended loads.

- 1.18. Remove brackets from the frame 58.

**NOTES:** Remove and save tie-down fitting.

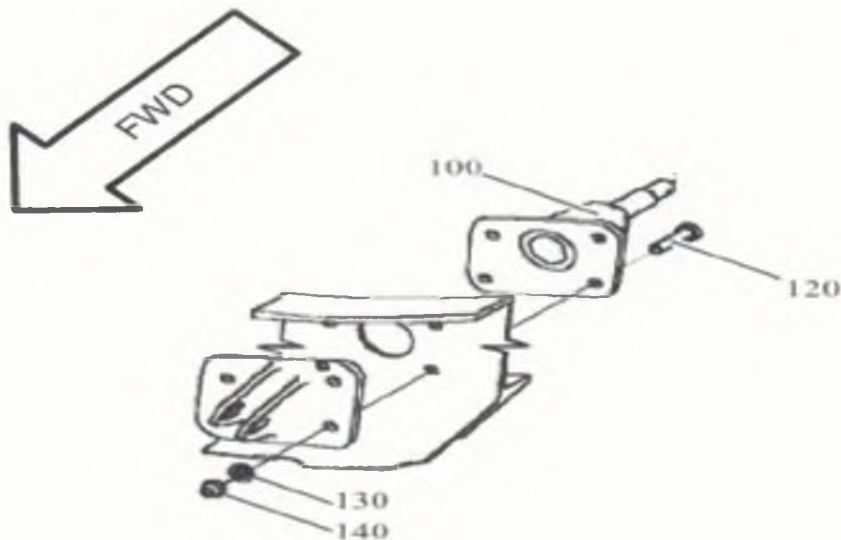

Figure 26. Left fitting, right opposite.

- 1.19. To perform a visual inspection for damage.  
In case of cracks detection A/C operation must be stopped, information immediately sent to SCAC.

## 1.20. Repair:

Materials:

1. Splice plate 1 (fig. 29) – 1 qty.
2. Splice plate 2 (fig. 30) – 1 qty.
3. Rivet 4-9-АН.ОКс-ОСТ 1 34040-80 (Cyrillic) – 25qty.
4. Rivet 4-11-АН.ОКс-ОСТ 1 34047-80 (Cyrillic) – 25 qty.
5. Interlay Sealant RRJ-070-ГВ (Cyrillic) – 1 pack.
6. Adhesion promoter PR184 – 1 pack.
7. Alodine 1200 – 1 pack.
8. Primer ЭП-0215 (Cyrillic) – 500 ml.
9. Primer ЭП-076 (Cyrillic) – 500 ml.
10. Enamel ЭП-140 (grey) (Cyrillic) – 500 ml.

1.20.1. Begin to drill  $D=6\text{mm}$ , mill 3 mm with oval burr see fig.27.

**NOTES:** To ensure the roughness of the working surfaces not less than Ra 1.6. It is not allowed to have scuffs and score mark on the surfaces.

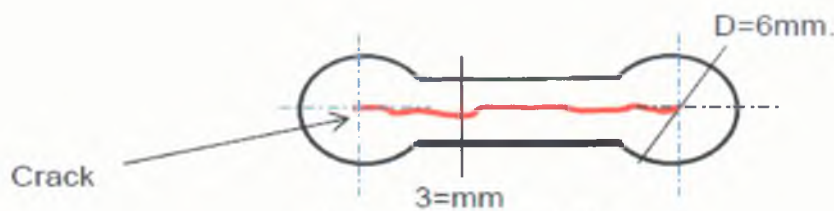

Figure 27. Spotdrill

1.20.2 Renew the corrosion protection afforded by Alodine 1200 according to SRM 51-21-02 and repaint protection according to SRM 51-23-04.

1.20.3 To produce splice plate of 12X18H10T thickness 1,5 mm see fig. 29,30, surface roughness Ra3.2, chemical passivation. The splice plate should be manufactured from metal sheet without additional treatment.

**NOTES:** Instead of Alodine 1200 is possible to use enamel ЭП-0215, 076 and ЭП-140. Do not apply enamel and primer on the splice plate with chemical passivation. Installation blind rivets with countersink  $90^\circ$ .

1.20.4 Perform the repair with the sealant RRJ-070-ГВ or alternative see Fig. 31,32,33,34.

1.20.5 Align the holes from the frame on the splice plate for mounting the brackets (pos. 100) see fig.35 and machined bolt holes (pos. 120) 6-24 Ц OCT 1 31103-80 per H12 with roughness Ra3.2.

- 4-11-Ан.Окс-ОСТ 1 34047-80 on the Web
- 4-11-Ан.Окс-ОСТ 1 34047-80 on the Belt
- 6-24 Ц ОСТ 1 31103-80 for mounting the brackets

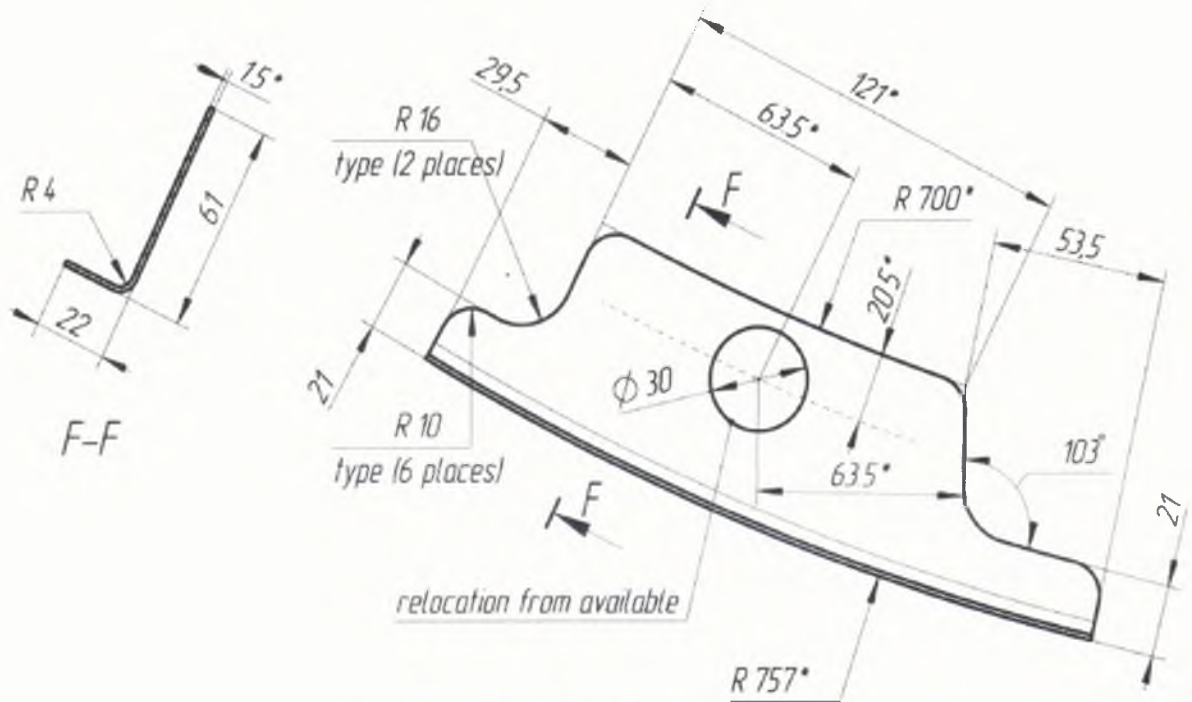

Figure 28. Splice plate/001

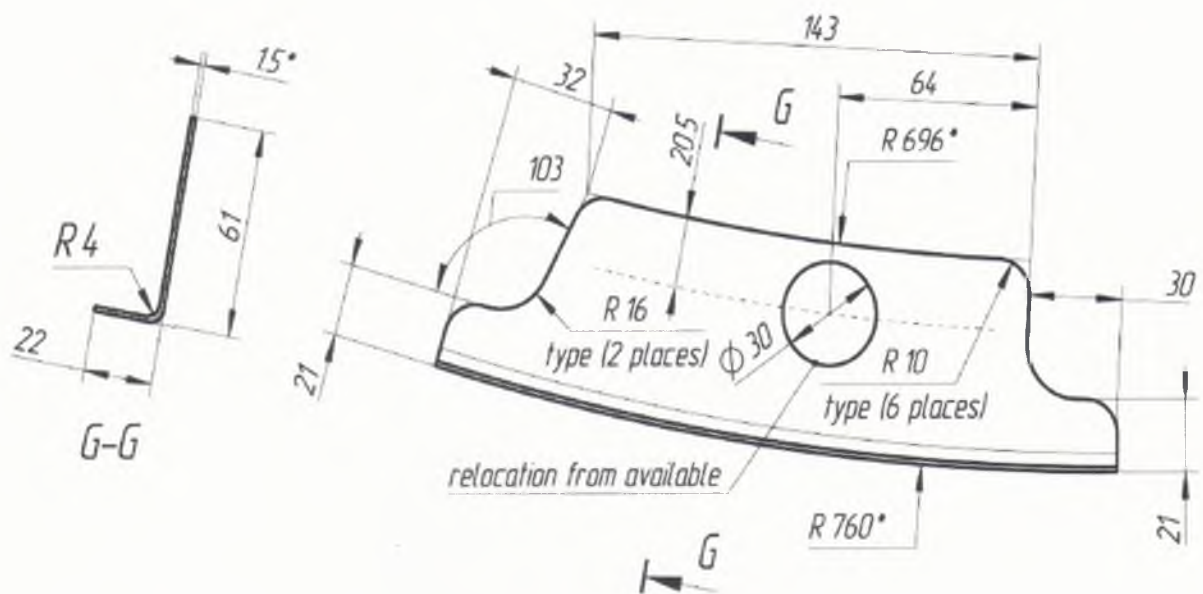

Figure 29. Splice plate/002



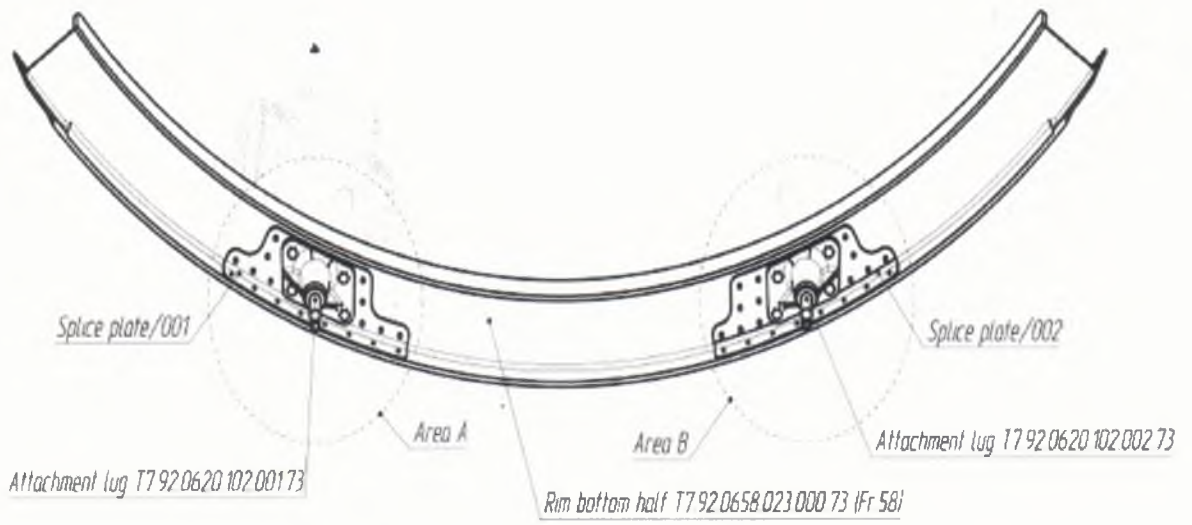

Figure 30. Installation of the splice plate. Front view

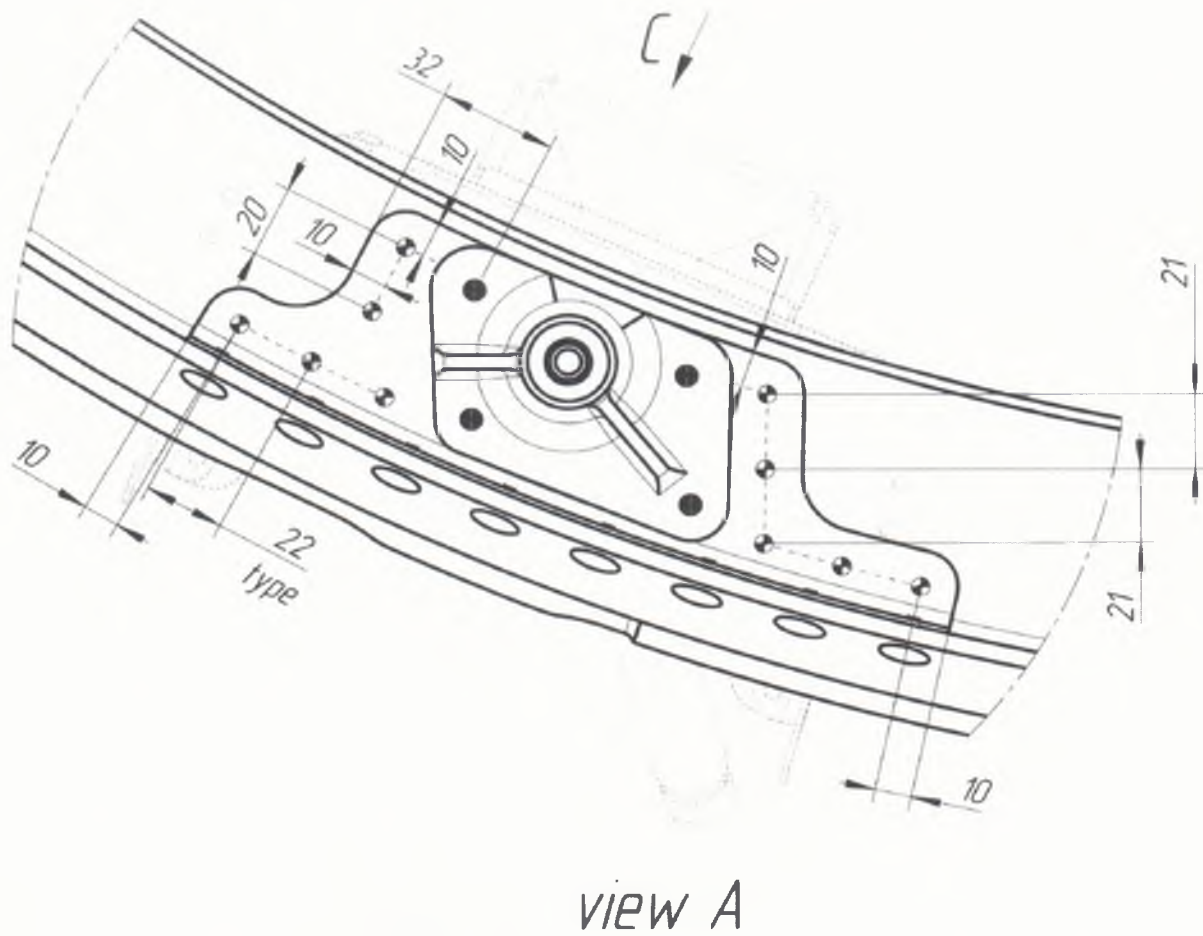
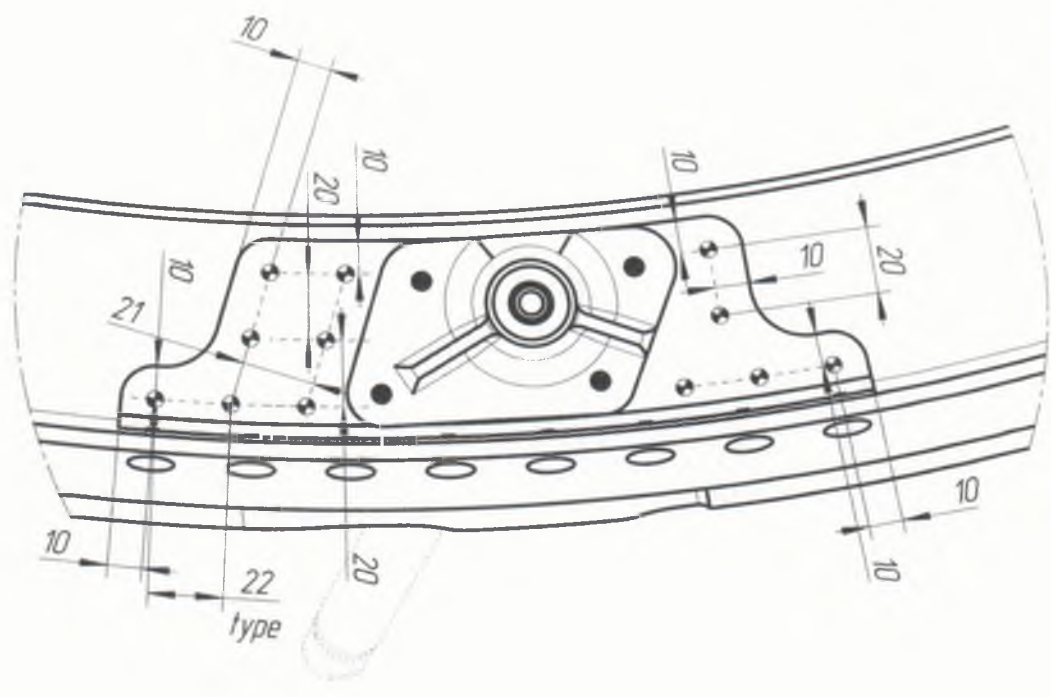
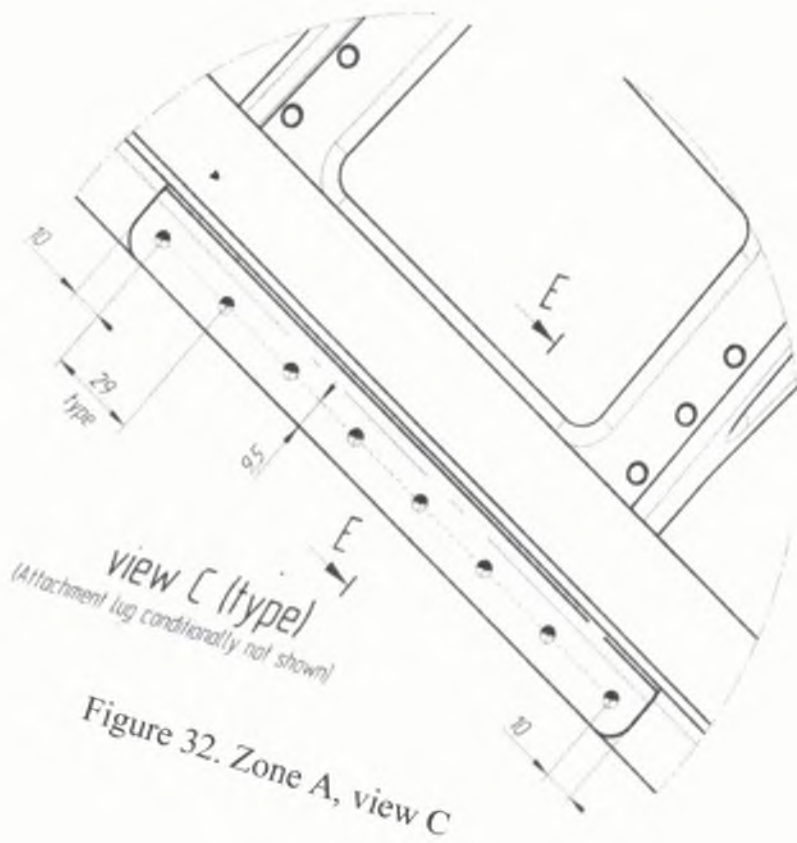

Figure 31. View A

type



By: A.A. Tsurkal  
Tel: 2025

RRJ0000-OR-470-1062

The final steps:

- 1.21. To install brackets on the previous disassembled bolts and washers 8qty. (4 qty. per each attach brackets). Bolts pos.120 is needed to open out on 180 degrees see Fig.34.

**NOTES:** Torque value for nut M = 7,1 H.M.

Fasten bolts and nuts with a primer ЭП-076 and enamel ЭП-140.

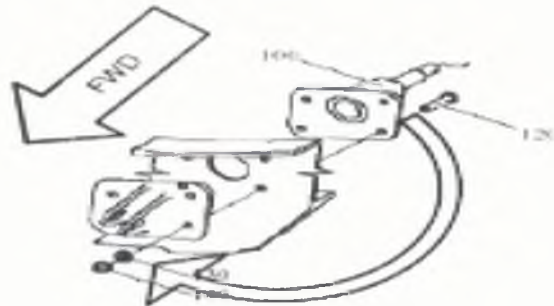

Figure 34 Left fitting, right opposite.

- 1.22. Remove the washers (150) from the pin (100) for temporary installation Section F6 for regulation F6. See Figure 35.

**NOTES:** Adjusting Washer can also be used on.

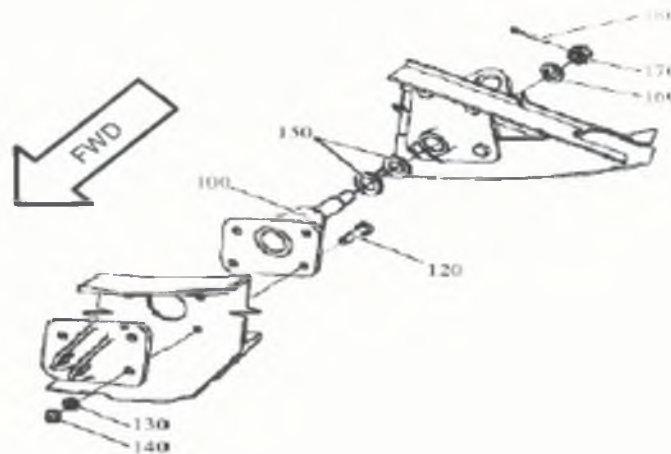

Figure 35

- 1.23. Installation Section F6, see Figure 20,21,22,23,24,25:

– To perform installation nut with sealant ЭПА or alternative. Grease 22;

**NOTES:** Torque value for nut M = 31,5 H.m.

- Cotter pin 2.5x25.02 ГОСТ 379-79 (Cyrillic) or alternative P/N MS24665-302;
- Fasten nuts and pin with a primer ЭП-076 and enamel ЭП-140 double thickness, cold drying;
- Remove tool for lifting;
- To install the left access door P/N T7.92.0861.100.000.70 and upper panel P/N T7.92.0845.100.000.70, screws P/Ns: 5-12-Ц-OCT 1 31538-80 and 5-14 - Ц-OCT 1 31538-80.

- 1.24. To install panels (see fig. 17):



- Left upper panel P/N T7.92.3125.175.003.73,
- Left lower panel P/N T7.92.3125.175.005.73,
- Left diaphragm P/N T7.92.3125.175.007.73,
- Right upper panel P/N T7.92.3125.175.004.73,
- Right lower panel P/N T7.92.3125.175.006.73,
- Right diaphragm P/N T7.92.3125.175.006.73.

**NOTES:** Use previously removed fasteners.

- 1.25. Perform installation of the elevator according to AMM 55-20-00-900-801.
- 1.26. Perform installation of the bonding strap F5 and F6 see Fig. 16(SWPM 20-40-70).
- 1.27. Perform ground point installation the firewall of frame from the F5 Section, see Fig. 15 (SWPM 20-40-70).
- 1.28. Perform installation of the fire extinguishing pipes from the firewall see Fig. 16 according to AMM 20-12-01-910-805.
- 1.29. Perform the air bleed duct installation, the clamp and pipe line see Fig. 13.  
**NOTES:** If the gasket was torn, replace the gasket.
- 1.30. Perform fuel pipeline P/N T7.92.6167.009.000.73 installation see Fig. 12.
- 1.31. Perform installation of the previous disassembled clamps see Fig.6,7,8,9,10,11.
- 1.32. Perform installation of the electrical connector and the bonding straps the firewall of frame 58 from the F5 Section see Fig. 5,4,3,2,1 (SWPM 20-10-00, 20-40-70, 20-10-00, 20-40-70, 20-10-00).
- 1.33. Degrease with cleaning solvent, apply red enamel ЭП-140 on the nuts.
- 1.34. Perform installation of the APU according to AMM 49-11-01-400-801.
- 1.35. Perform visual inspection of the APU Fuel System Units according to AMM 49-31-00-210-801; AMM 20-12-01-910-801 and operational test of the Air Bleed Pipe from the APU AMM 36-12-10-900-801; AMM 49-00-00-860-802.
- 1.36. Perform operational test of the Auxiliary Power Unit lights according to AMM 33-32-00-710-801.
- 1.37. Perform operational test of the Navigation Lights according to AMM 33-44-00-710-801.

## **IMPLEMENTATION OF INSPECTIONS AND FURTHER OPERATION**

By: A.A.Tsurkal

Tel: 2025

**RRJ0000-OR-470-1062**

Repair Validity: Temporary  
3 months/1000 FH/500 FC

Inspection interval: 50 FC

Perform the inspection after the repair.

Periodic inspection in accordance with AMM 53-86-00-220-803 «Detailed Inspection of Frame 58» detection of cracks. Detailed Inspection of the Attach Fittings in Section F5.

The preparation work and the final work for repair activities are carried out the RRJ-95 aircraft Operators or with a certified MRO. Repairs would be carried out and paid for by SCAC.

**ATTACHMENT 1:**

Tool for lifting Section F6 p/n F7.40.11.0800.011.000.00.-A

