

Implementation of Measures to Prevent Objects Falling off Airplanes

January 2018

Civil Aviation Bureau of Japan,
Ministry of Land, Infrastructure, Transport and Tourism
Association of Air Transport Engineering and Research



Table of Contents

Foreword

Chapter 1 Types of objects falling off airplanes

1.1 Parts Departing Airplane (PDA) events

1.2 Survey of ice accumulation on aircrafts

Chapter 2 Measures against PDA

2.1 Examples of inspections and modifications (including design changes) for PDA prevention

(1) Boeing

(2) Airbus

2.2 Proactive Japanese airlines' activities to reduce PDA events

(1) Sharing information and calling attention to PDA events

(2) Additional checks and inspections

(3) Introduction of improved parts

(4) Thorough implementation of basic tasks

Chapter 3 Measures against ice blocks falling

3.1 Causes and preventive measures

(1) Ice accumulation near potable water service panels

(2) Ice accumulation near fuselage drains

(3) Ice accumulation on cargo doors

(4) Ice accumulation on drain masts

(5) Monitoring of ice accumulation

Chapter 4 Summary

Conclusion

Appendix 1 Boeing's examples of the inspection and modification (including design change) to prevent PDA

Appendix 2 Airbus's examples of the inspection and modification (including design change) to prevent PDA

Appendix 3 Calling attention using posters summarizing past PDA events

- (1) Boeing 737 (B737)
- (2) Boeing 767 (B767)
- (3) Boeing 777 (B777)
- (4) Boeing 787 (B787)
- (5) Airbus A320 (A320)
- (6) Bombardier DHC-8-400 (Q400)

Foreword

It is an important issue for Japan to enhance the functions of airports in the Tokyo metropolitan area, in order to cope with hosting the 2020 Tokyo Olympics and Paralympics successfully, to strengthen the international competitiveness of the Tokyo metropolitan area and to accommodate the increase in the number of foreign visitors to Japan, linking the Tokyo metropolitan area and other various areas in Japan with the rest of the world.

To increase the number of flights at Tokyo International Airport (Haneda Airport) and strengthening the functions of airports in the Tokyo metropolitan area, it is necessary to use its runways in the most efficient way possible, considering noise and safety. Therefore, it is necessary to establish flight paths to/from each runway taking into consideration obstacles on the ground, separations between aircrafts, and compliance with international standards. As a result of the study based on these criteria, we have determined that the most efficient approach is from the metropolitan city-center when the wind is out of the south. Therefore, we are aiming to establish flight routes that are suitable for this condition.

When establishing these new flight routes, it is crucial to ensure not only the airplanes' safety but also the overall operational safety, because objects falling off airplanes may harm third parties on the ground, and therefore, these events could make headlines in the society. Although we have taken preventive actions against objects falling off airplanes, including thoroughly performing maintenance and inspection of airplanes, we still have to take further actions to protect people's lives and property from being damaged, considering recent incidents of objects falling off airplanes.

For this purpose, we publish this guidance material to make Japanese and foreign airlines as well as relevant organizations familiar with concrete measures to prevent objects falling off airplanes, and help them strengthen activities against objects falling off airplanes.

In editing this guidance material, we interviewed maintenance staff, ground handling staff, and other relevant staff as well as visited many sites to research the measures to prevent objects falling off airplanes including the daily tasks of Japanese airlines. In addition, the aircraft manufacturers provided us with technical information considered useful for preventing PDA. We would like to take this opportunity to express our great appreciation to the parties concerned who gave us their cooperation.

Chapter 1 Types of objects falling off airplanes

There are two types of objects falling off airplanes: parts and ice blocks.

1.1 Parts Departing Airplane (PDA) events

Number of reported PDA events

Figure 1-1 indicates the number of PDA events, discovered by Japanese operators, during maintenance inspections and other tasks. 451 events were reported during the eight year period from April 1, 2009 to March 31, 2017 (FY2009 to FY2016). Figure 1-2 indicates the percentage of the total PDA by part classification.

Note that object to be reported are as follows:

- 1) Non-metallic parts: 100 cm² or more in area, or 200 g or more in weight; or
- 2) Metallic parts: 100 cm² or more in area, or 100 g or more in weight; or
- 3) Rubber seals: 100 cm or more in length, or total loss of exterior light.

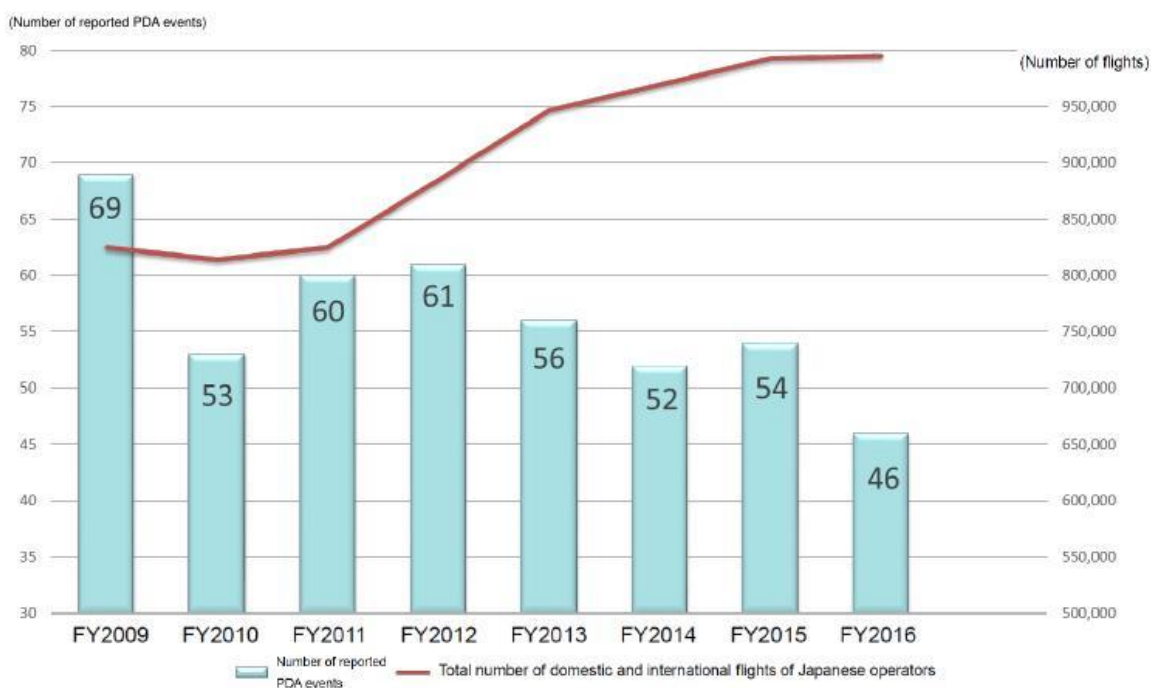

Figure 1-1: Trend of the number of reported PDA events

While the number of departures/landings has been increasing, the number of reported PDA events has not been going up due to the efforts to reduce PDA events by the operators as well as the efforts to improve aircraft design by the manufacturers. However, a certain number of PDA events have been occurring. We have to continue and further strengthen our preventive actions to reduce PDA events more.

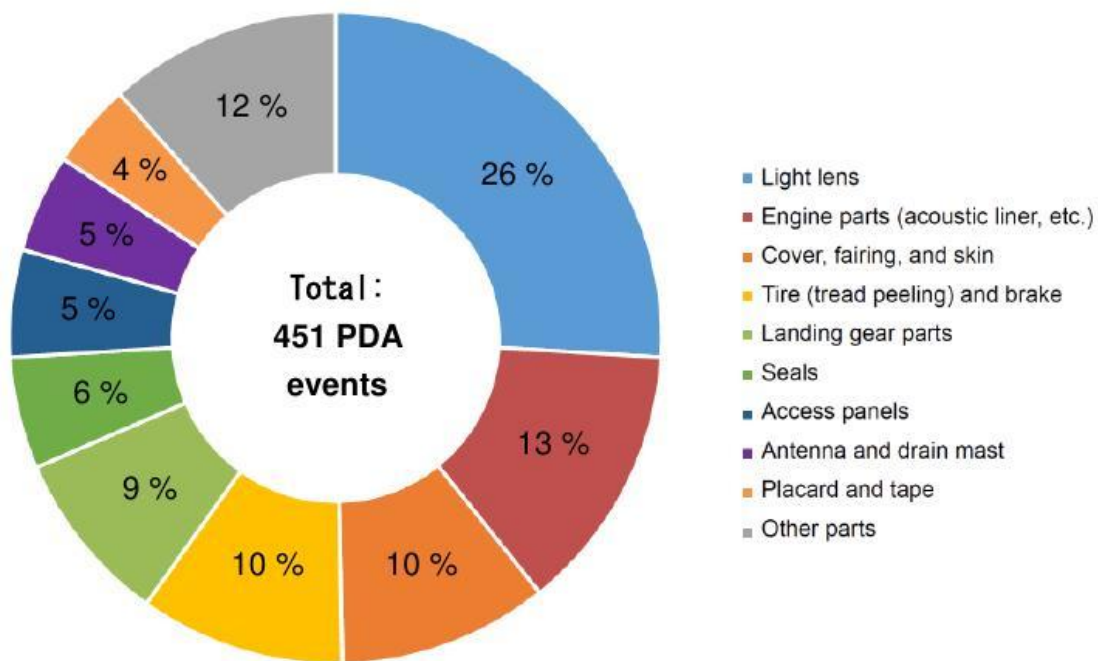

Figure 1-2: Classification of reported PDA events by part

The most common parts are exterior lights (including lens covers, etc.), which account for 26% of the total, followed by engine parts (acoustic liner, etc.) which make up 13%; cover, fairing and skin 10%; tire (tread peeling) and brakes 10%; landing gear parts 9%; seals 6%; access panels 5%; antenna and drain mast 5%; and placard and tape 4%.

1.2 Survey of ice accumulation on aircrafts

An ice block is an accumulation of ice that is formed during flight specifically on the surface of an aircraft, from fluids that have leaked out of an airplane due to failure of the lavatory/potable water service and drain systems, etc. or inappropriate services on the ground. In addition to this, ice blocks are generated from moisture in the atmosphere, which condenses and freezes on the surface of an airplane, as well as when snow and ice are thrown up from the ground during takeoff. When an aircraft descends to a lower altitude, these ice blocks could depart from the aircraft and fall to the ground as outside temperatures rise or due to airframe vibrations. Instances of damage to properties on the ground caused by these ice blocks falling have been reported.

Shown below, for reference, is the result of a survey of ice accumulation on aircrafts, which was conducted at Narita International Airport by Narita International Airport Corporation in FY2016.

Survey of Ice Accumulation on Aircrafts (FY2016) by Narita International Airport Corporation

a. Purpose

This report is compiled to help prevent accidents in the area around Narita International Airport caused by pieces of ice that have fallen from aircraft. It is based on a survey of arriving aircraft conducted at Narita International Airport. The survey checks ice build-up on aircraft (drain valves, drain mast, landing gear, flaps and service panels), analyzes the probable cause and proposes procedures to prevent ice accumulation.

b. Outline of the Survey

1) Survey period and location

The survey was conducted at Narita International Airport from 11 to 24 January 2017 (10 days except Saturdays, Sundays).

2) Aircraft checked

All aircraft arriving at Narita International Airport from 8:00 a.m. to 5:00 p.m. were surveyed (Except: Private jet). However, aircraft landing under special circumstances (e.g. emergency landings, etc.) were excluded.

3) Procedure

- A visual inspection for ice accumulation was made by walking around the aircraft immediately after its arrival at its stand.
- If ice accumulation was observed, the condition was recorded by still camera or

video recorder.

- After obtaining permission from the airline, a sample of the ice was collected. Flight information (e.g. airport of departure, weather conditions during the flight, etc.) was also collected from the airline.

- Survey findings were logged in a monitor report sheet and, following an on-site inspection of the aircraft, that data was used to hypothesize the cause of the ice build-up.

- The ice samples were sent to the Narita Airport Office of the Ministry of Land, Infrastructure, Transport and Tourism for a chemical analysis.

- Measurements of fuselage skin temperatures were recorded to collect data correlating fuselage skin temperatures and ice accumulation.

c. Summary of Survey Results

1) Survey summary

Total no. of aircraft arrivals

(In the 10 days, excl. Sat., Sun.) : 3,286

Total no. of aircraft checked: 1,728

No. of aircraft where ice accumulation was found: 37

Percentage of aircraft checked in the 10 days: 52.59 % (=1,728/3,286)

Percentage of aircraft with ice accumulation: 2.14 % (= 37/1,728)

2) Analysis by area with ice accumulation

As a result of the survey of ice accumulation on aircraft in FY2016, the areas with ice accumulation were found to be as follows:

① Fuselage drain	29 cases (14 flights)
② Potable water service panel	3 cases
③ Drain mast	1 case
④ Air-conditioning service panel	10 cases (7 flights)
⑤ Potable water overflow port	1 case
⑥ Fuselage aft of landing gear	1 case
⑦ Landing gear and landing gear wheel well	3 cases (2 flights)
⑧ Cargo door	2 cases
⑨ Wing/fuselage skin	7 cases

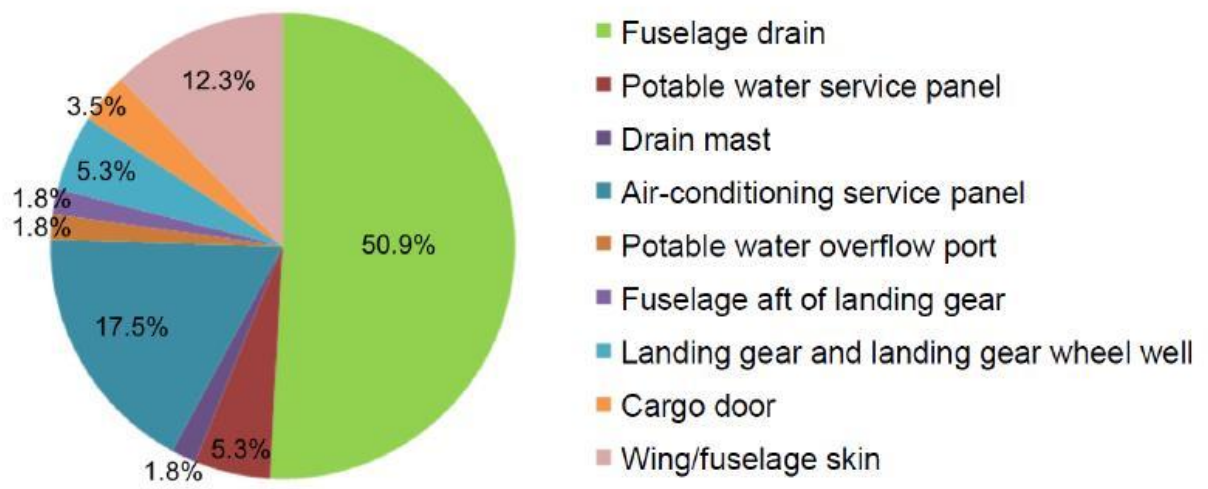

Figure 1-3: Percentage of areas with ice accumulation

Chapter 2 Measures against PDA

Improper design, wear and abrasion due to repeated use, human error in manufacturing or maintenance of aircraft, and other causes (such as Foreign Object Damage) are typically considered as the root causes for PDA. Generally, operators and aircraft manufacturers investigate the causes, and conduct additional inspections or modifications of the items to prevent recurrence. The aircraft manufacturers provide information to the operators by issuing technical information such as “Service Bulletins” (SB). Each operator evaluates and examines the technical information and then adopts them into their fleets based on the priority. It is important to actively accomplish those recognized information to achieve a highly effective prevention action to reduce PDA events.

Therefore, it is important to report all PDA events to the aircraft manufacturers. Airline reporting is critical in identifying areas for improvement and the involvement of operators is critical to addressing PDA issues. It is also important that the aircraft manufacturers eradicate the causes of PDA by reviewing every reported PDA events, developing solutions for recurrence and providing communications appropriately by issuance of technical information such as SBs in order to reduce PDA events. Airlines should eliminate the potential for PDA by accomplishing the SBs and implementing the corrective action(s) such as repetitive inspections or a terminating modification.

2.1 Examples of inspections and modifications (including design changes) for PDA prevention

(1) Boeing (Refer to Appendix 1.)

Model	Title	Material 1
B737	DOORS – Landing Gear Doors – Inboard Main Landing Gear Door Hinge Fittings – Inspection and Replacement (SB 737-52A-1167)	Fig. 1-1
B737	WINGS – Trailing Edge Flaps – Inboard Main Flap Seal Fastener Change (SB 737-57-1331)	Fig. 1-2
B737	FUSELAGE – Fillet Fairings – Aft Wing to Body Fairing – Panel 194E and Aft Center Wheel Well Panel 193D – Inspection and Rework (SB 737-53-1307)	Fig. 1-3
B737	WINGS – Leading Edge And Leading Edge Devices – Krueger Flap Inspection (SB 737-57A-1327)	Fig. 1-4
B747	FUSELAGE – Wheel Wells – Nose Landing Gear Forward Door Operator Rod Bolt Replacement (SB 747-53-2894)	Fig. 1-5
B767	WINGS – Trailing Edge and Trailing Edge Devices – Outboard Flap Support Rib Nut Fracture Inspection (SB 767-57A-0131)	Fig. 1-6

B767	FLIGHT CONTROLS - Flaps - Outboard Flap Deflection Control Track -Inspection/Replacement (SB 767-27-0184)	Fig. 1-7
B767	LANDING GEAR – Main Landing Gear and Doors – Main Gear Shock Strut Door and Linkage – Mid and Lower Attach Fitting Hardware Replacement (SB 767-32-0194)	Fig. 1-8
B767	LANDING GEAR – Main Landing Gear Bogie Beam Pivot Joint Pin Replacement (SB 767-32A-0199)	Fig. 1-9
B777	AILERONS AND FLAPERONS – Aileron Leading Edge Rib Addition And Fixed Trailing Edge Seal Replacement (SB 777-27-0022)	Fig. 1-10
B777	FUSELAGE – Section 44 – Aerodynamic Fairings – Underwing Fairing Access Doors – Rigging and Latch Replacement (SB 777-53-0050)	Fig. 1-11
B777	FUSELAGE – Aerodynamic Fairings – Right Upper Aft Fairing Panel Assembly Misfair Inspection/Replacement (SB 777-53-0056)	Fig. 1-12
B777	WINGS – Wing Trailing Edge – Inboard Fixed Trailing Edge Support Beam Replacement (SB 777-57-0093)	Fig. 1-13
B777	POWER PLANT (PW4000) – EXHAUST – THRUST REVERSER – UPPER BIFURCATION EROSION SHIELD – ADDITION (SB 777-78-0022)	Fig. 1-14
B787	FUSELAGE – Main Landing Gear Wheel Well Structure – Section45 – Aft Wheel Well Bulkhead Heat Shield Click Bond Revision (SB 787-53-0022)	Fig. 1-15

(2) Airbus (Refer to Appendix 2.)

Model	Title	Material 2
A320	DOORS – CARGO COMPT DOOR HYD SYSTEM – IMPROVE LOCKING AND INTERFACE TOLERANCE OF MANUAL SELECTOR VALVE (MSV) LEVER (SB A320-52-1160)	Fig. 2-1
A320	NACELLE & PYLON – AFT MOVABLE FAIRING – RIB 5 REDESIGN (SB A320-54-1028)	Fig. 2-2
A320	STABILIZERS – RUDDER SIDE SHELL SANDWICH REPAIR INSPECTION (SB A320-55-1041)	Fig. 2-3
A320	POWER PLANT – FAN COWL DOORS – INTRODUCE AN IMPROVED OIL FILLER DOOR LATCH DESIGN ON IAE ENGINE (SB A320-71-1061)	Fig. 2-4
A320	APPLY SHL TECHNOLOGY ON LANDING LIGHTS (TFU33.42.00.004)	Fig. 2-5
A330	FUSELAGE – REAR FUSELAGE – RELOCATE VHF 2 ANTENNA (SB A330-53-3112)	Fig. 2-6

A330	DOORS – SERVICE DOORS – IMPROVE SERVICE PANEL ACCESS DOORS IN SECTION 16 AND 18 (SB A330-52-3108)	Fig. 2-7
A330	DOORS – SERVICE DOORS – MODIFICATION OF LATCHING MECHANISM OF POTABLE WATER SERVICE PANEL (SB A330-52-3086)	Fig. 2-8

2.2 PDA-prevention measures implemented by Japanese airlines

This section introduces the PDA-prevention measures implemented by Japanese airlines.

(1) Sharing information and calling attention to PDA events (Refer to Appendix 3.)

The information on the occurrence of PDA events is documented by accountable airline staff and is shared with relevant departments. In addition, the information on past PDA events is compiled into a poster for each aircraft model and these posters are posted in offices and other various places for the purpose of sharing information as well as calling their attention. Before maintenance staff and ground handling staff head for apron, they review the posters and raise their awareness of preventing PDA so that they can better find symptoms of PDA such as improperly secured access panels, loosened hinges and protrusion of seals not only in the areas where PDA occurred in the past, but also in other areas.

(2) Additional checks and inspections

As a measure to ensure aircraft safety and to prevent the recurrence of PDA, Japanese airlines conduct additional inspections of their aircrafts which are the same models that have experienced PDA events previously. If necessary, they will introduce a repetitive inspection into their maintenance program.

In addition, they make efforts to prevent PDA events by sharing information with other airlines which operate aircraft of the same model.

(3) Introduction of improved parts

Japanese airlines actively report PDA/ice blocks falling events to the aircraft manufacturers when they have experienced the events. They also actively modify their aircrafts and install improved parts which they consider to be effective for PDA/ice blocks falling.

Replacing existing parts with improved ones is recommended as a preventive measure against PDA through technical documents such as Service Bulletins (SB) and Service Letters (SL) will be issued by aircraft and components manufacturers. Japanese airlines actively adopt such SBs and SLs which they consider can effectively prevent PDA events.

(4) Thorough implementation of basic tasks

Maintenance staff in Japanese airlines check twice by pointing and calling, and use other methods to ensure the locking of access panels when closing them and the proper installation of parts when restoring them. They also communicate fully with ground handling staff about the condition of the aircraft and share the information with the ground handling staff, in order to detect signs of PDA/ice blocks falling.

Flight crews perform exterior walkarounds based on the check list before each flight, in order to ensure that there is no impact damage to the structure and all ground access doors are closed.

11

Chapter 3 Measures against ice blocks

In order to enhance the effectiveness of measures against ice accumulation, it is important to disseminate information about the prevention of ice accumulation and to ensure that staff in ground handling companies as well as airline technicians conduct their work following the basic procedures.

3.1 Causes and preventive measures

(1) Ice accumulation near potable water service panels

If the panel is not closed correctly or draining is insufficient after potable water servicing, ice blocks may form on the service panel and around it due to water leaks during flight. It is important to ensure that excess water is discharged after servicing, and it is also important, in particular, to completely drain water from the fill fitting itself. (Figure 3-1: Example of ice accumulation on potable water service panel and Figure 3-2: Example of ice accumulation on fill fitting (Potable water service panel))



Figure 3-1: Example of ice accumulation on potable water service panel



Figure 3-2: Example of ice accumulation on fill fitting (Potable water service panel)

A potable water drain is equipped to discharge water from the potable water system during maintenance work. However, improper switching of an internal valve or failure of an internal valve itself may cause a water leak into the drain line from the potable water system and may possibly result in ice accumulation.

If a regular inspection task includes cleaning of the drain valve to maintain its functions properly and even a little water leak is found in daily water service, it is important to suspect if there may be a valve failure and immediately report it or inform the mechanics in charge of the aircraft.

Also, with regards to lavatory waste system, it is effective to confirm that no water is leaking from around the waste tank service panel and the cap is put properly. In addition, it is also effective to wipe off remaining moisture after cleaning the service panels and doors to prevent ice accumulation.

(2) Ice accumulation near fuselage drains

An aircraft sometimes accumulates liquid inside the fuselage skin, which is why an aircraft has many drain holes on the lower part of the fuselage to discharge accumulated liquid, etc.

The drains of the pressurized area (fuselage) are fitted with drain valves, and the drain valves are normally closed by the difference in pressure between the inside and outside of the aircraft during flight above a certain altitude, and are opened below that certain altitude to discharge accumulated water in the aircraft. Some drain holes in the non-pressurized areas (those corresponding to the outer panel of the fuselage such as fairings) have no drain valves. If water is generated in the non-pressurized area, the water is always discharged outside of the aircraft.

Accumulated water in the pressurized areas is mainly due to condensation that occurs inside the fuselage skin. However, it can also be due to rain or snow remaining on cargo (such as containers). Therefore, weather conditions at the point of departure can also contribute to ice accumulation. The main cause of accumulated water in the non-pressurized area is a leak from the drain valves inside the fuselage.

There are two conceivable mechanisms by which ice blocks form: One is that a drain valve has not been closed properly due to a temporary failure or dust clogging and this results in a water leak during flight; the other is that, when the difference in pressure between the inside and outside of the aircraft declines below certain altitude, the drain valve opens and the leaking water is exposed to the outside cold air. (Figure 3-3: Example of ice accumulation on fuselage drain)

The drain valves of all models are required to be inspected and cleaned in periodical maintenance. Therefore, it is imperative that the function of these valves be maintained properly in order to prevent water from leaking to the outside of an aircraft during flight so that ice accumulation can be reduced. In addition, it is necessary to follow basic standards such as ensuring the complete removal of accumulated snow on cargo in order to prevent moisture from entering the cargo compartment. Further, it is important to follow the recommendations about ice accumulation on the cargo door as described in the next section.



Figure 3-3: Example of ice accumulation on fuselage drain

(3) Ice accumulation on cargo doors

Ice accumulation on the cargo door may be caused by water leak or snow accumulation on cargo. It is important to remove moisture completely from the cargo and wrap it properly before loading. Take note of the following points:

- a. Make sure that cargo that has a potential for water leaks has been appropriately packed and wrapped in a way that it is judged to be robust enough for air transportation.
- b. When cargo is temporarily stored outdoors, appropriate measures shall be taken to prevent damage caused by rain and snow.
- c. Any snow and ice remaining on the cargo or unit loading device shall be removed before loading cargo on the aircraft.
- d. When containers and baggage are loaded in the cargo compartment, rainwater and snow on them shall be removed before they are carried in.
- e. If it is stormy when cargo is loaded and there is a possibility that a large amount of rainwater has got inside, be very careful.



Figure 3-4: Example of ice accumulation along the edge of the lower part of cargo door

(4) Ice accumulation on drain masts

A drain mast is installed to discharge water from the galley and lavatory wash-basins. It is always heated during flight and controlled to prevent water from freezing. A failure of this heating function may cause ice blocks to form. It is important to confirm that the heating function of these areas works properly at the time of maintenance.



Figure 3-5: Drain mast

(5) Monitoring of ice accumulation

It is important to monitor the ice accumulation on the aircraft, investigate the cause of ice accumulation, including ice accumulated outside the aircraft during flight and accumulation due to snow and ice thrown up by tires on the ground, disseminate information on the prevention of ice accumulation, and implement recurrence-prevention measures.

Chapter 4 Summary

Efforts considered to be effective to prevent PDA and ice blocks falling have been summarized in this chapter. It is necessary to promote these efforts in cooperation with operators, aircraft manufacturers, ground handling companies, and the aviation authorities. Details of these efforts are described in Chapter 2 and Chapter 3, and it is important for each operator to take appropriate measures based on the following points:

1. Share information on experienced PDA events with manufacturers, and make necessary efforts for investigation on their causes and recurrence prevention. In addition, compile data on the locations where PDA and ice accumulation have occurred in the past and properly inform staff on daily basis.
It is important to carry out tasks in accordance with the procedures in the manual.
2. Actively adopt SBs and SLs from aircraft and component manufacturers when the technical information included in such documents is recognized to be an effective measure to prevent objects falling off airplanes.
3. As a recurrence-prevention measure, inspect all aircraft of the same model that have experienced PDA events. Introduce periodical inspections into the maintenance program for those aircraft as needed and implement the repetitive inspections. In addition, share information with other airlines that operate aircrafts of the same model as needed to prevent PDA.
4. Make sure that there is no water leak from the service panels, wipe off moisture completely according to the work procedures after the servicing of potable water as a measure to prevent ice accumulation, and thoroughly follow the basic procedures. The same handling is also effective with regard to water discharge of the wastewater system. In addition, remove the snow and rainwater accumulated on cargo and around the cargo door completely when the cargo is loaded.
5. Monitor the presence of ice on an aircraft, and investigate the cause of ice accumulation outside of the aircraft during flight or due to snow and ice thrown up by tires. It is important to share information about the prevention of ice accumulation and implement recurrence-prevention measures.

Conclusion

In order to ensure the safety of people/property on the ground as well as the safety of aircraft operations, it is important to make efforts to prevent PDA and ice blocks falling. It is also important to ensure aviation safety in close cooperation with the aviation authorities, airlines, aircraft manufacturers and all relative parties such as ground handling companies. We hope that this "Implementation of Measures to Prevent Objects Falling off Airplanes" will be of some help to prevent objects falling off airplanes in the future.

Appendix 1

Boeing's examples of the inspection and modification
(including design change) for PDA prevention

Model	Title
B737	DOORS – Landing Gear Doors – Inboard Main Landing Gear Door Hinge Fittings – Inspection and Replacement (SB 737-52A-1167)

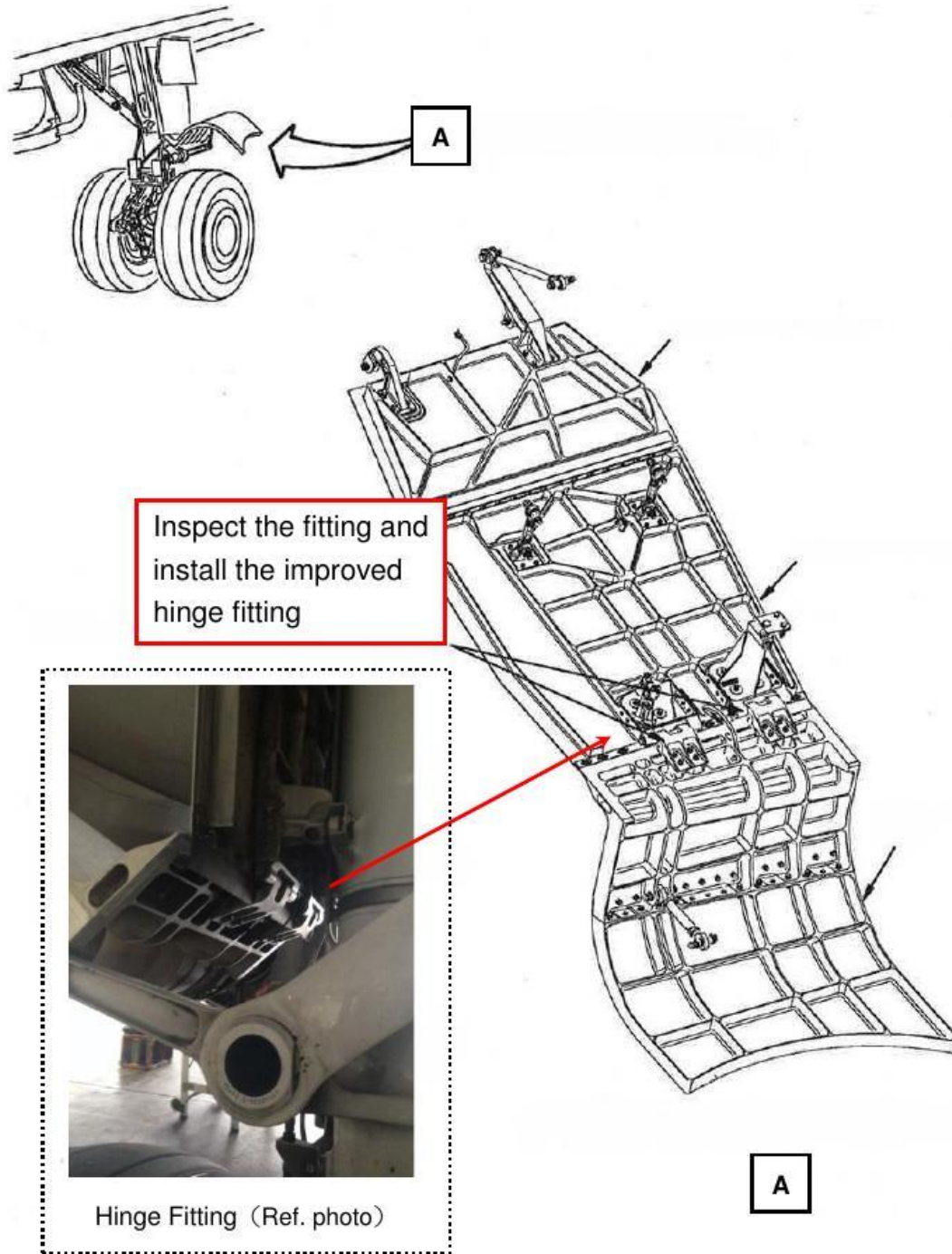

Fig. 1-1

Model	Title
B737	WINGS – Trailing Edge Flaps – Inboard Main Flap Seal Fastener Change (SB 737-57-1331)

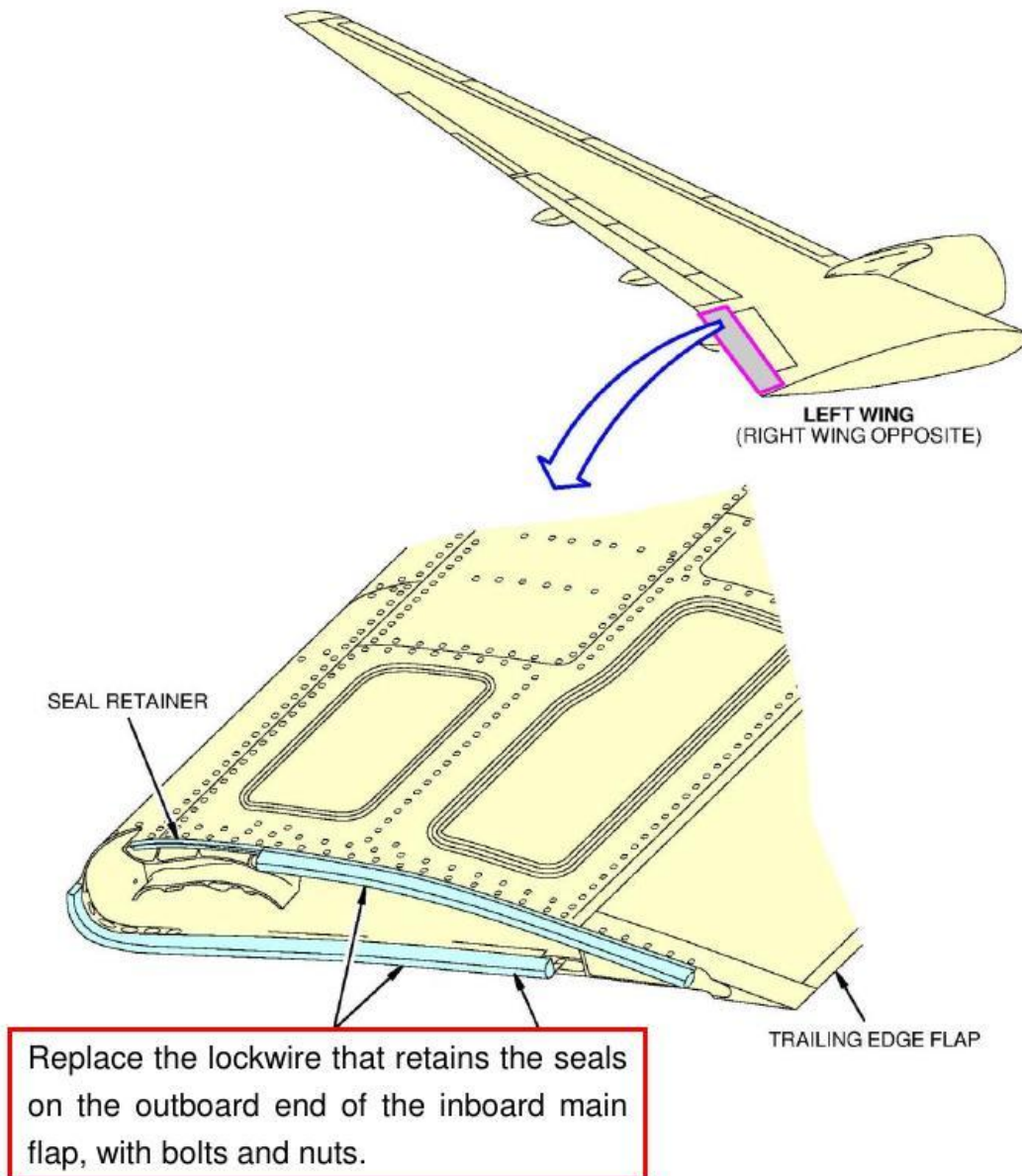

Fig. 1-2

Model	Title
B737	FUSELAGE – Fillet Fairings – Aft Wing to Body Fairing – Panel 194E and Aft Center Wheel Well Panel 193D – Inspection and Rework (SB 737-53-1307)

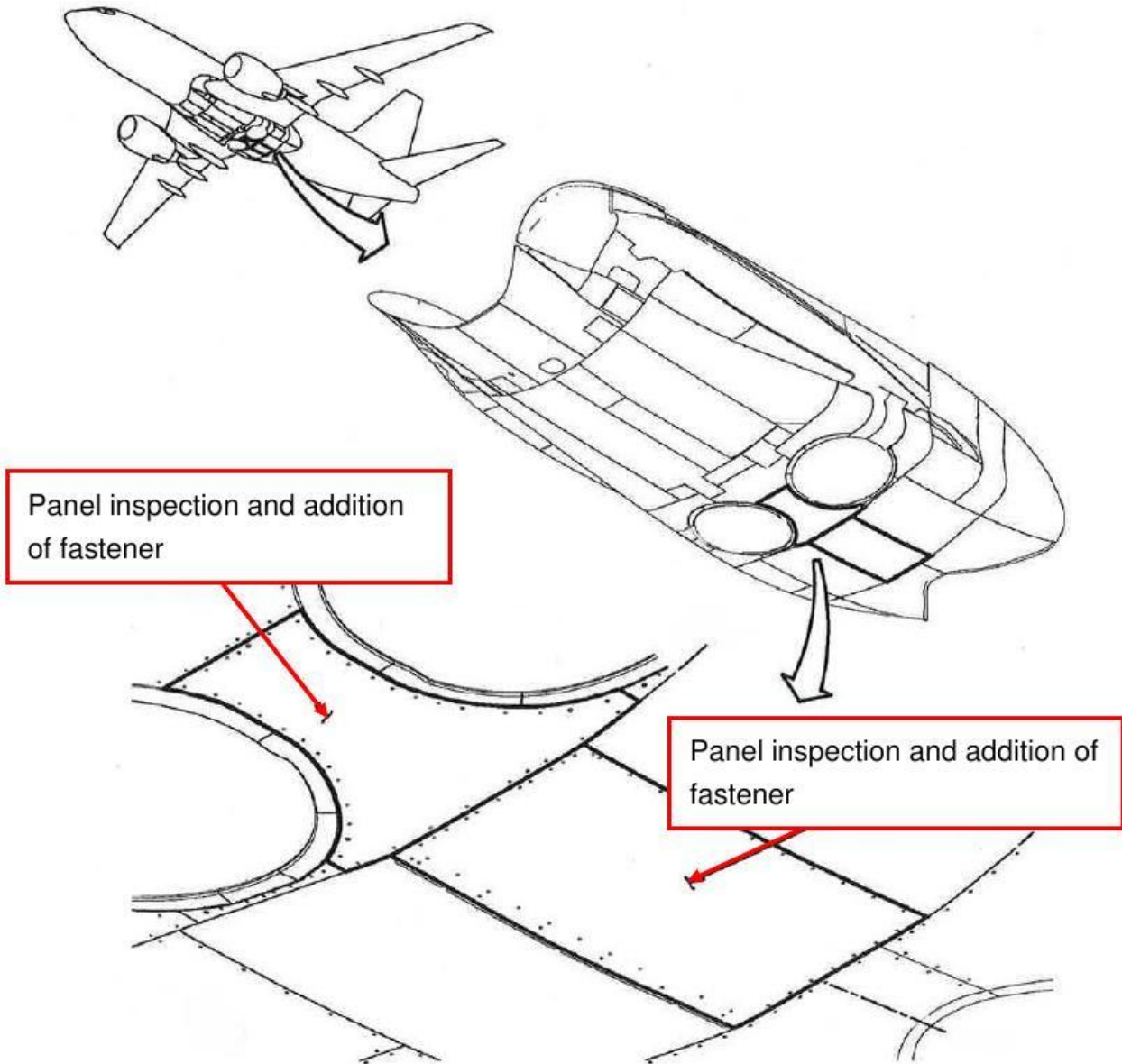

Fig. 1-3

Model	Title
B737	WINGS – Leading Edge And Leading Edge Devices – Krueger Flap Inspection (SB 737-57A-1327)

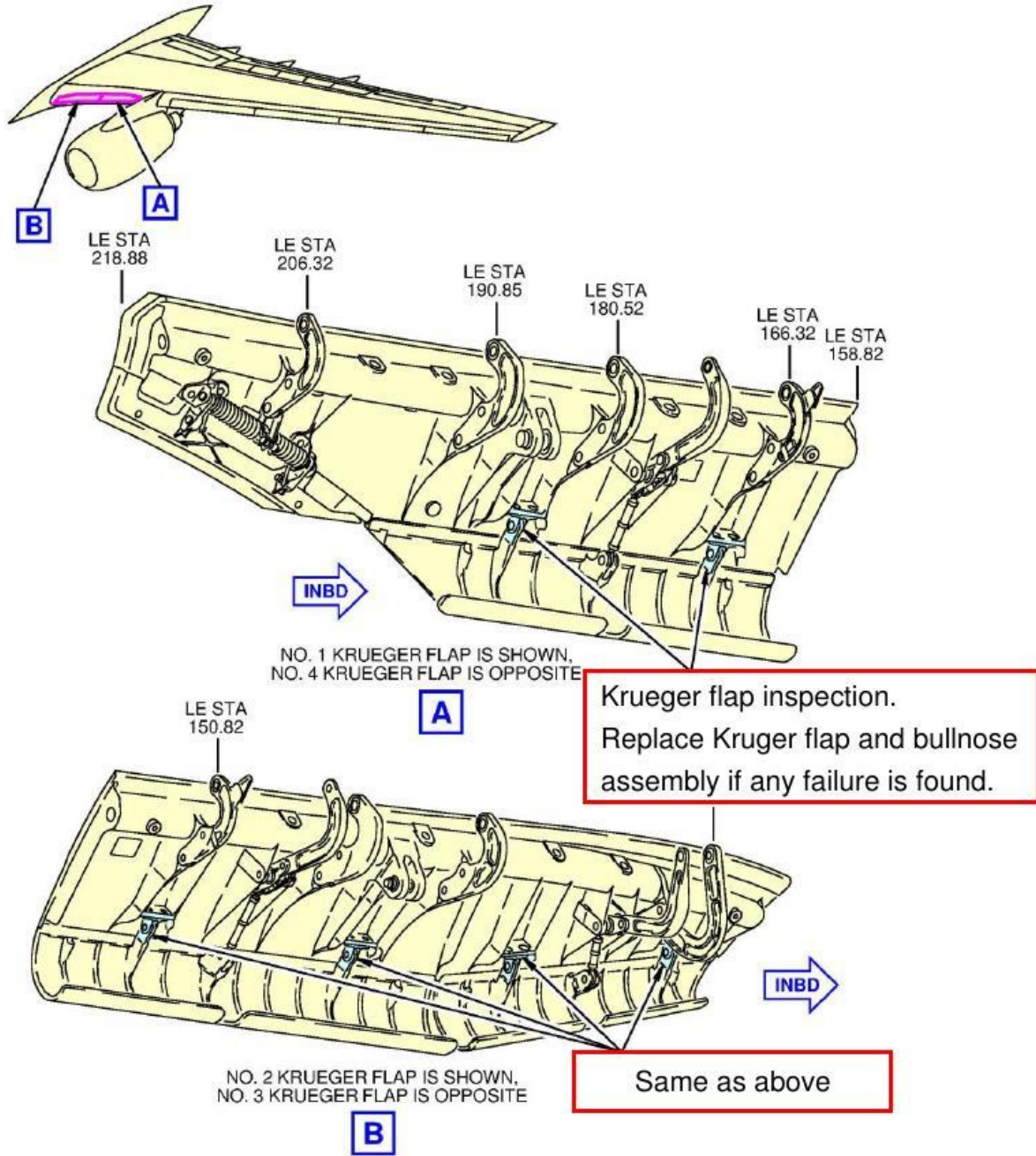

Fig. 1-4

Model	Contents of Measure
B747	FUSELAGE – Wheel Wells – Nose Landing Gear Forward Door Operator Rod Bolt Replacement (SB 747-53-2894)

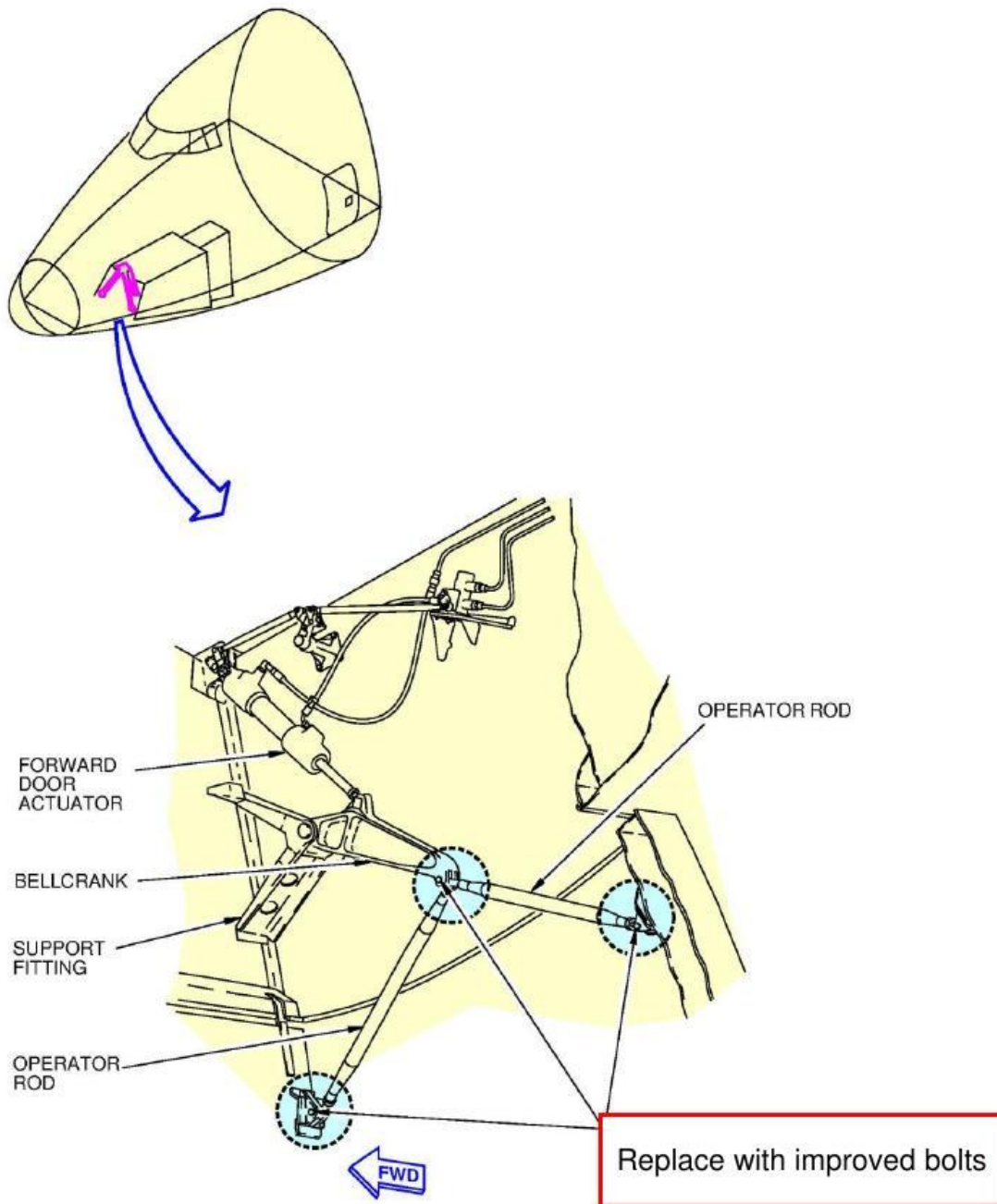

Fig. 1-5

Model	Title
B767	WINGS – Trailing Edge and Trailing Edge Devices – Outboard Flap Support Rib Nut Fracture Inspection (SB 767-57A-0131)

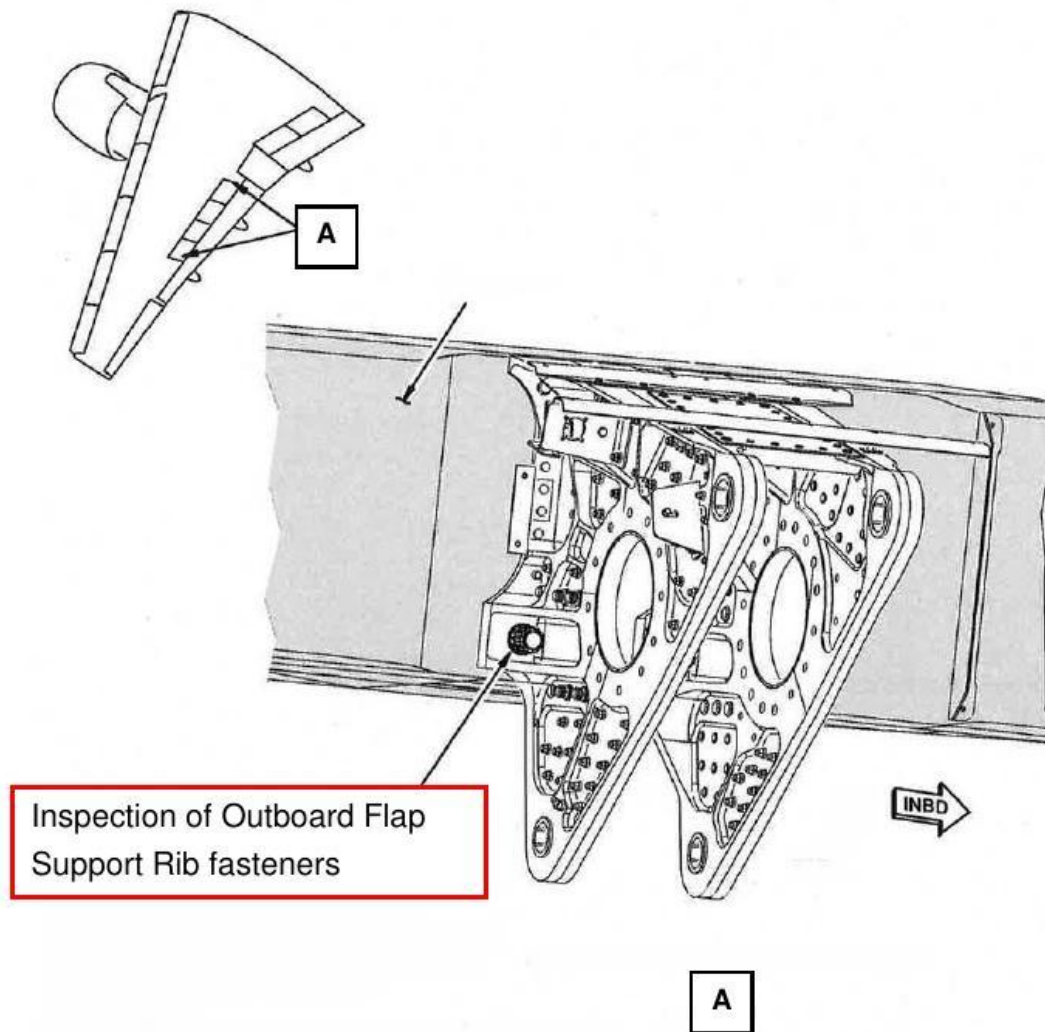

Fig. 1-6

Model	Title
B767	FLIGHT CONTROLS - Flaps - Outboard Flap Deflection Control Track -Inspection/Replacement (SB 767-27-0184)

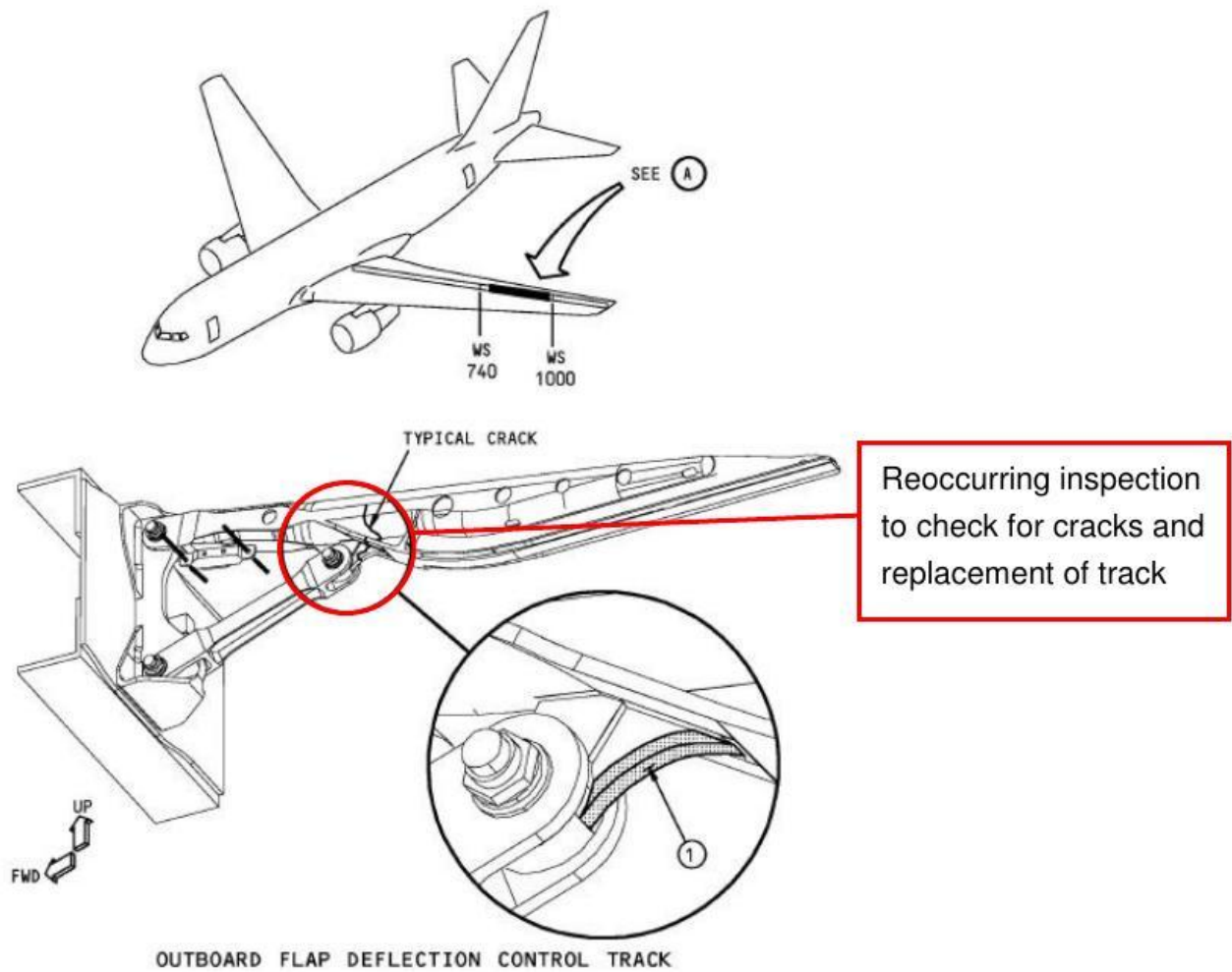

Fig. 1-7

Model	Title
B767	LANDING GEAR – Main Landing Gear and Doors – Main Gear Shock Strut Door and Linkage – Mid and Lower Attach Fitting Hardware Replacement (SB 767-32-0194)

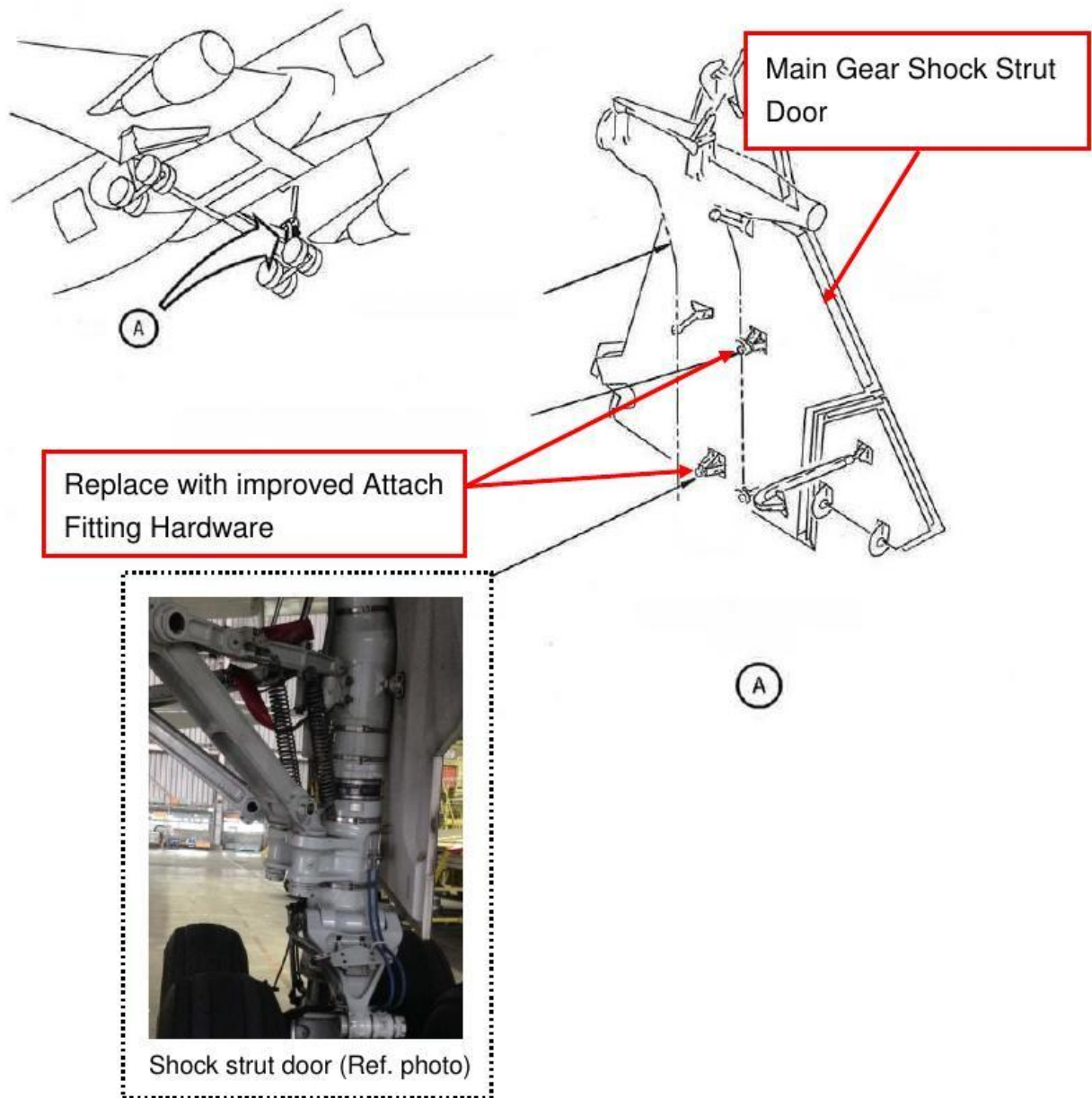

Fig. 1-8

Model	Title
B767	LANDING GEAR – Main Landing Gear Bogie Beam Pivot Joint Pin Replacement (SB 767-32A-0199)

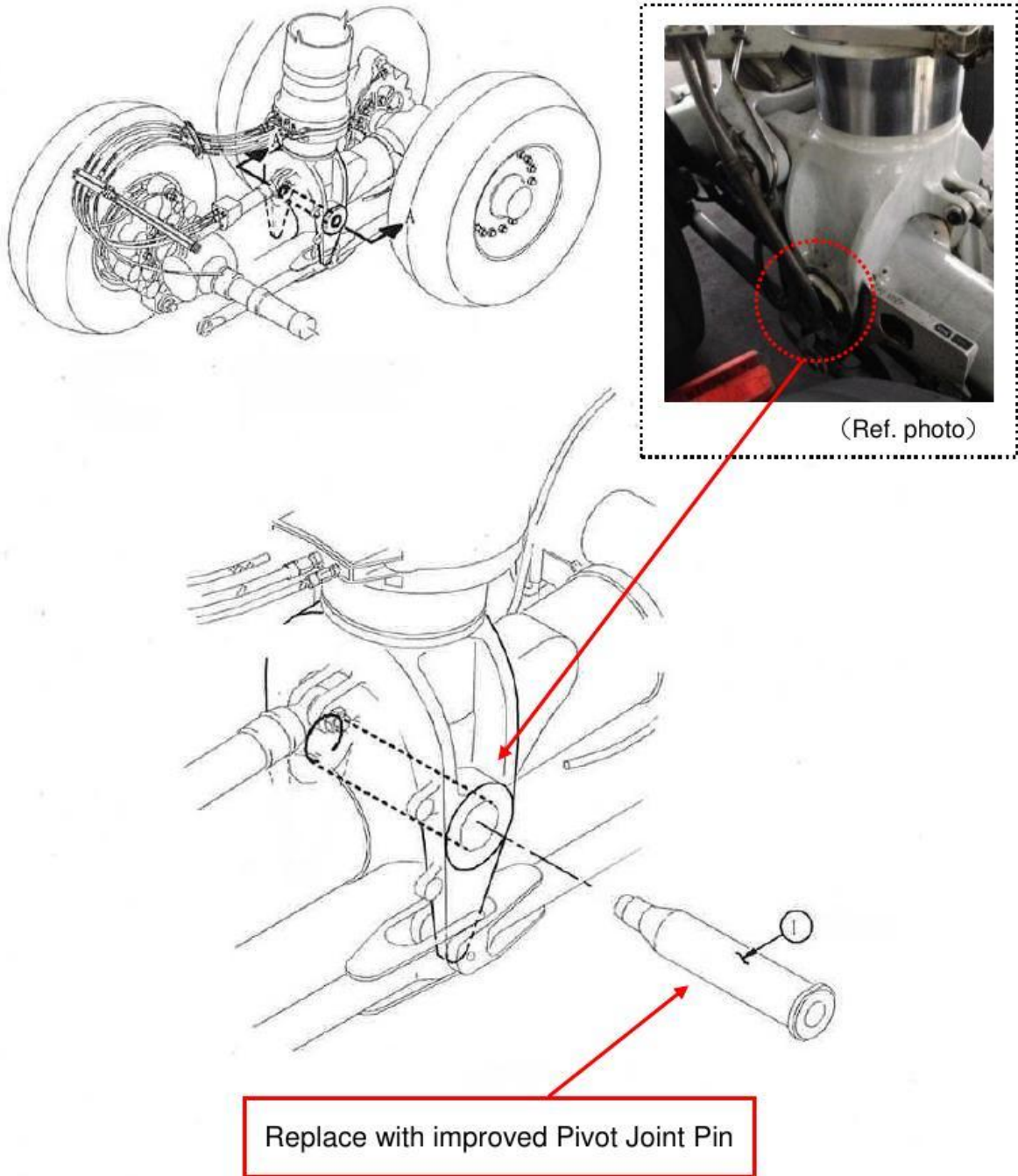

Fig. 1-9

Model	Title
B777	AILERONS AND FLAPERONS-Aileron Leading Edge Rib Addition And Fixed Trailing Edge Seal Replacement (SB 777-27-0022)

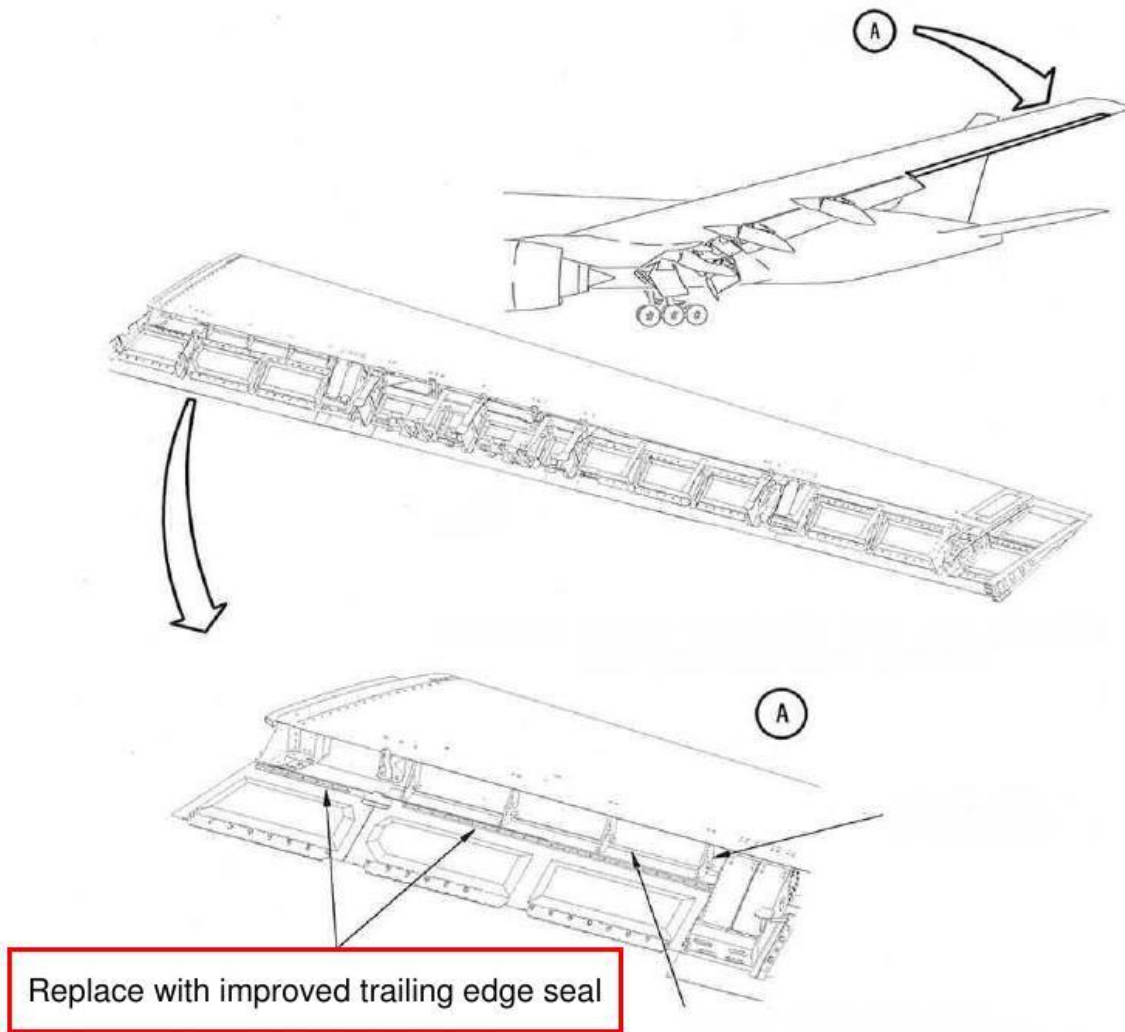

Fig. 1-10

Model	Title
B777	FUSELAGE - Section 44 - Aerodynamic Fairings - Underwing Fairing Access Doors - Rigging and Latch Replacement (SB 777-53-0050)

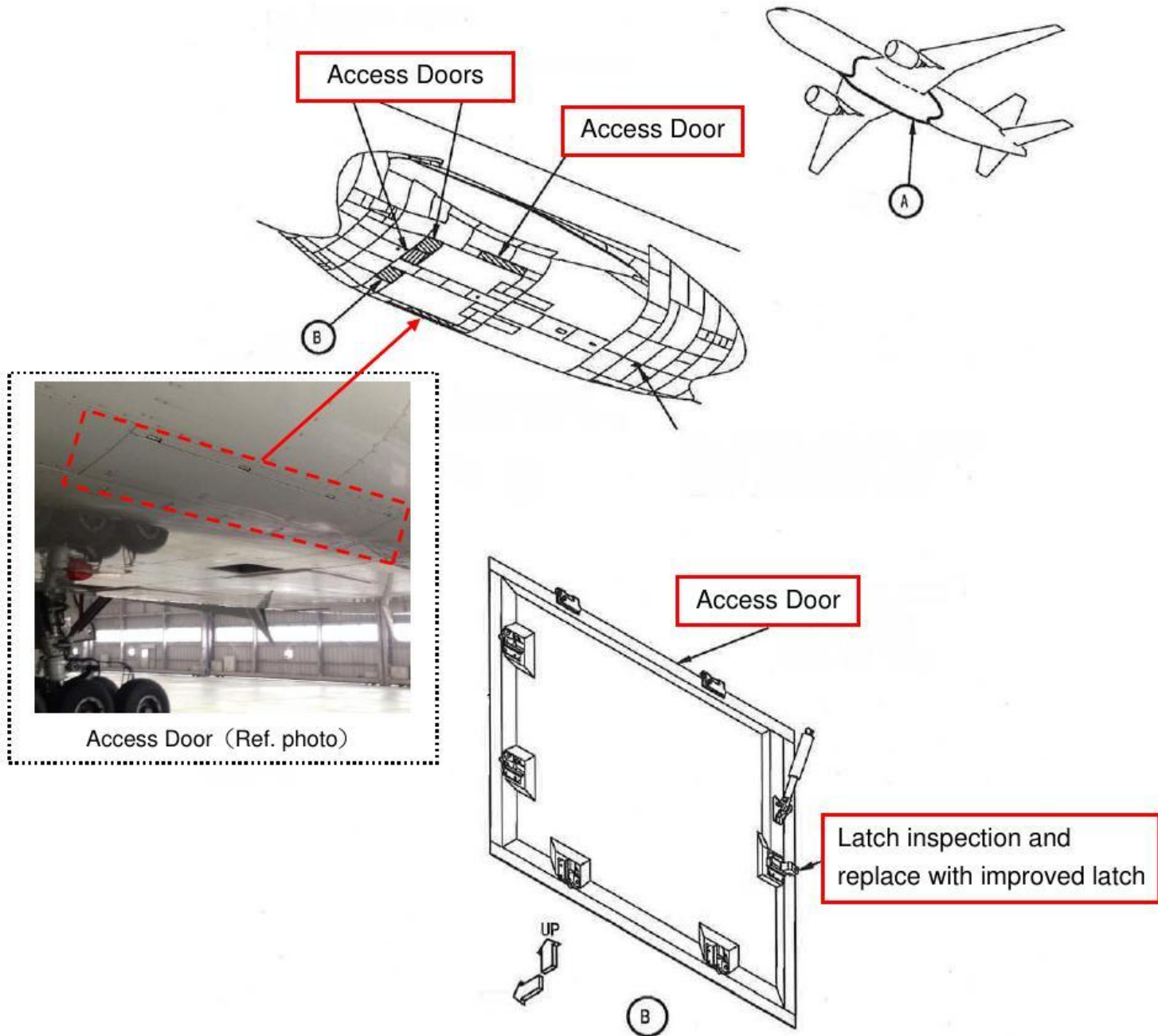

Fig. 1-11

Model	Title
B777	FUSELAGE - Aerodynamic Fairings - Right Upper Aft Fairing Panel Assembly Misfair Inspection/Replacement (SB 777-53-0056)

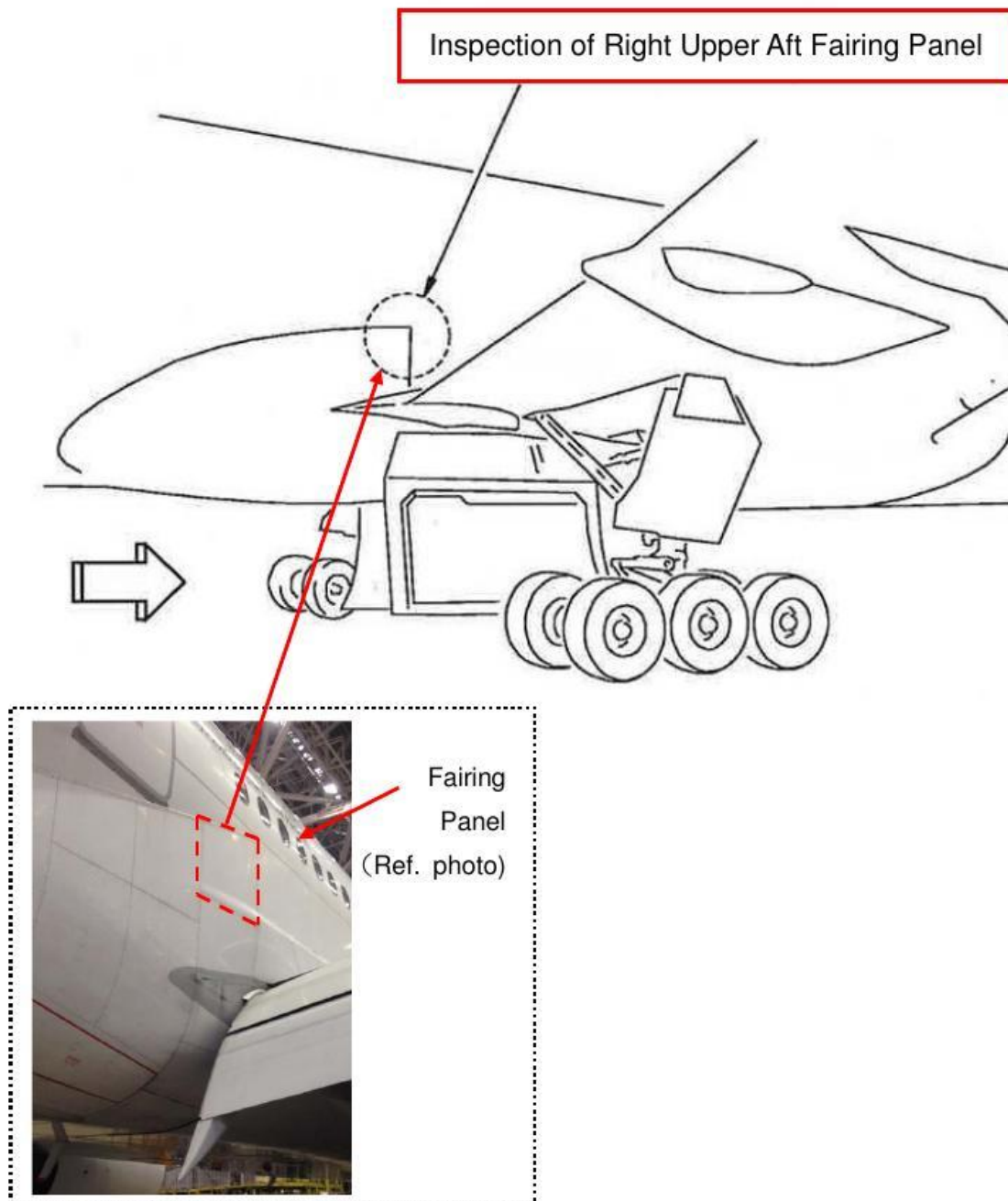

Fig. 1-12

Model	Contents of Measure
B777	WINGS - Wing Trailing Edge - Inboard Fixed Trailing Edge Support Beam Replacement (SB 777-57-0093)

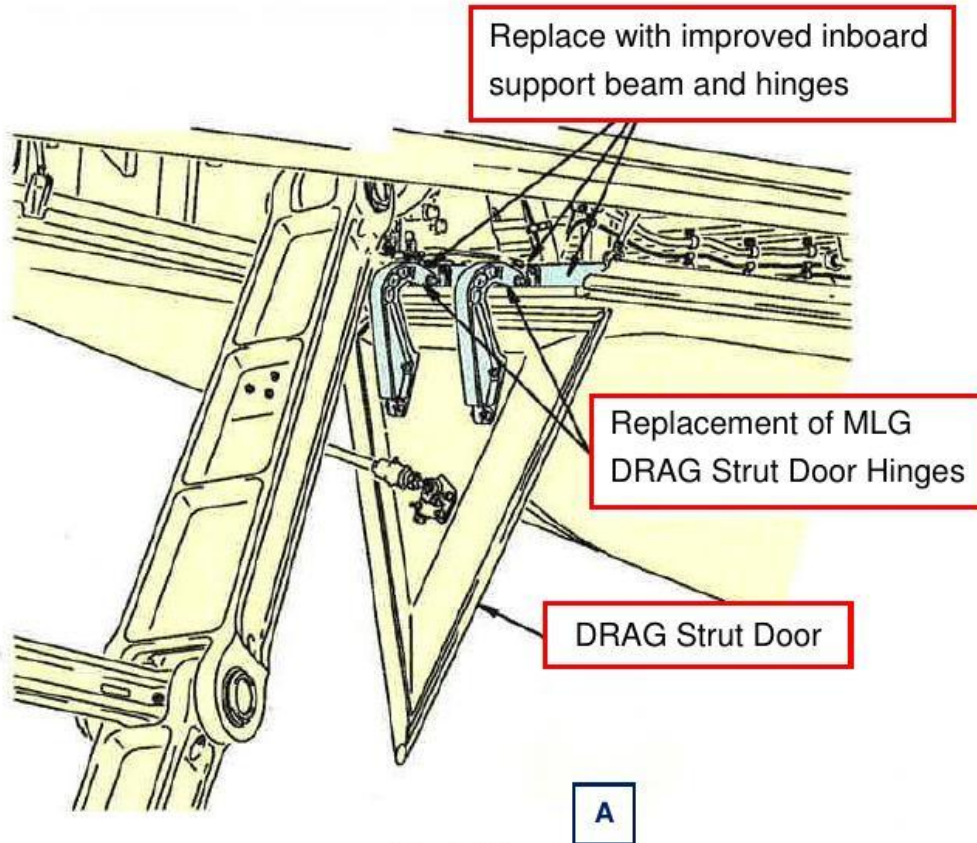
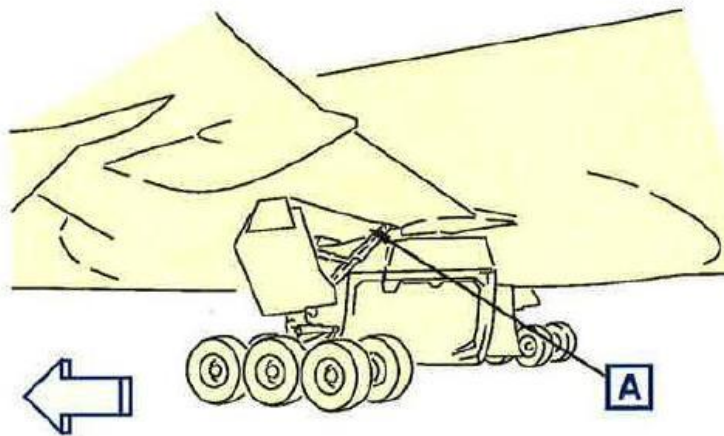

Fig. 1-13

Model	Title
B777	POWER PLANT (PW4000) - EXHAUST - THRUST REVERSER - UPPER BIFURCATION EROSION SHIELD – ADDITION (SB 777-78-0022)

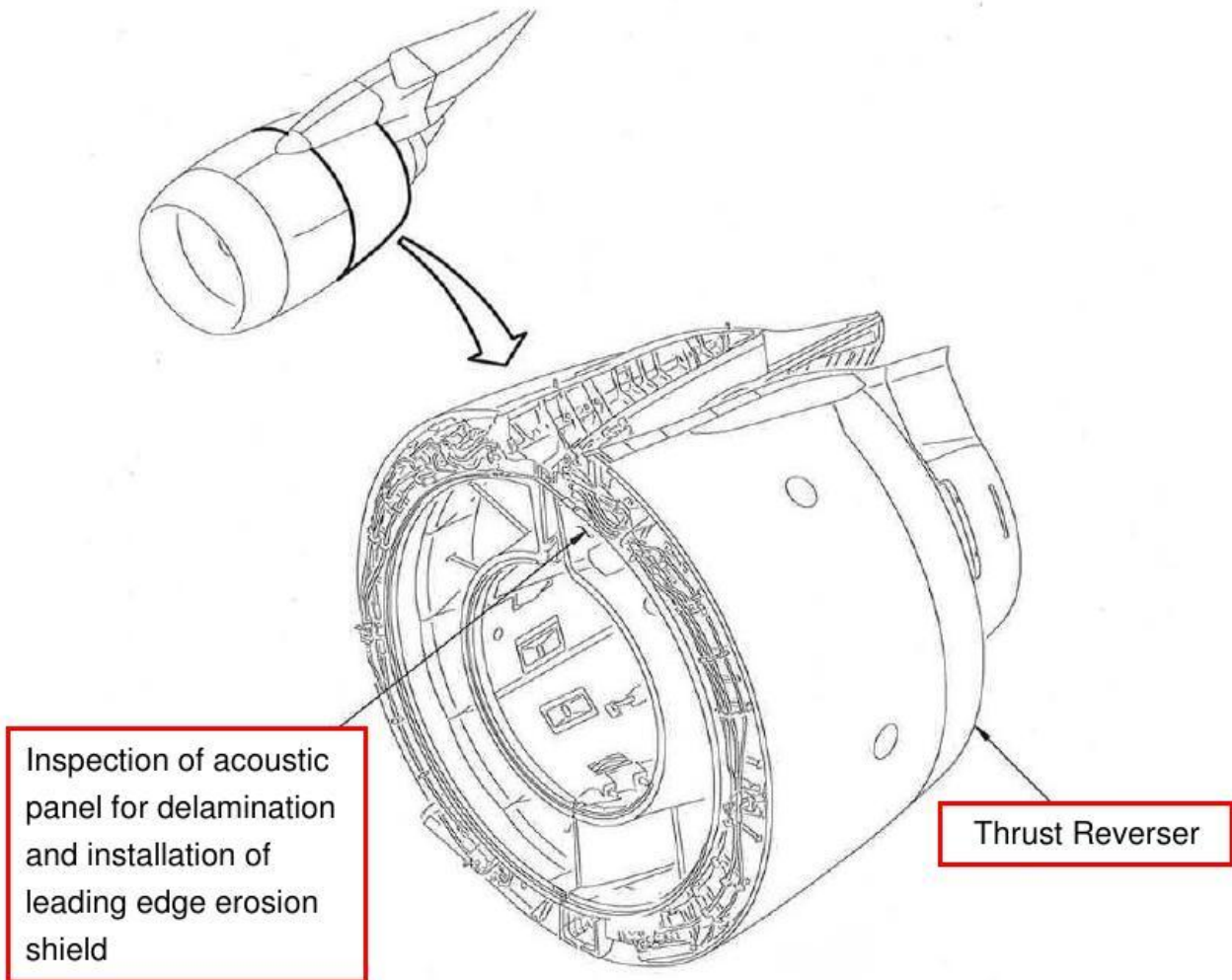

Fig. 1-14

Model	Title
B787	FUSELAGE - Main Landing Gear Wheel Well Structure – Section45 – Aft Wheel Well Bulkhead Heat Shield Click Bond Revision (SB 787-53-0022)

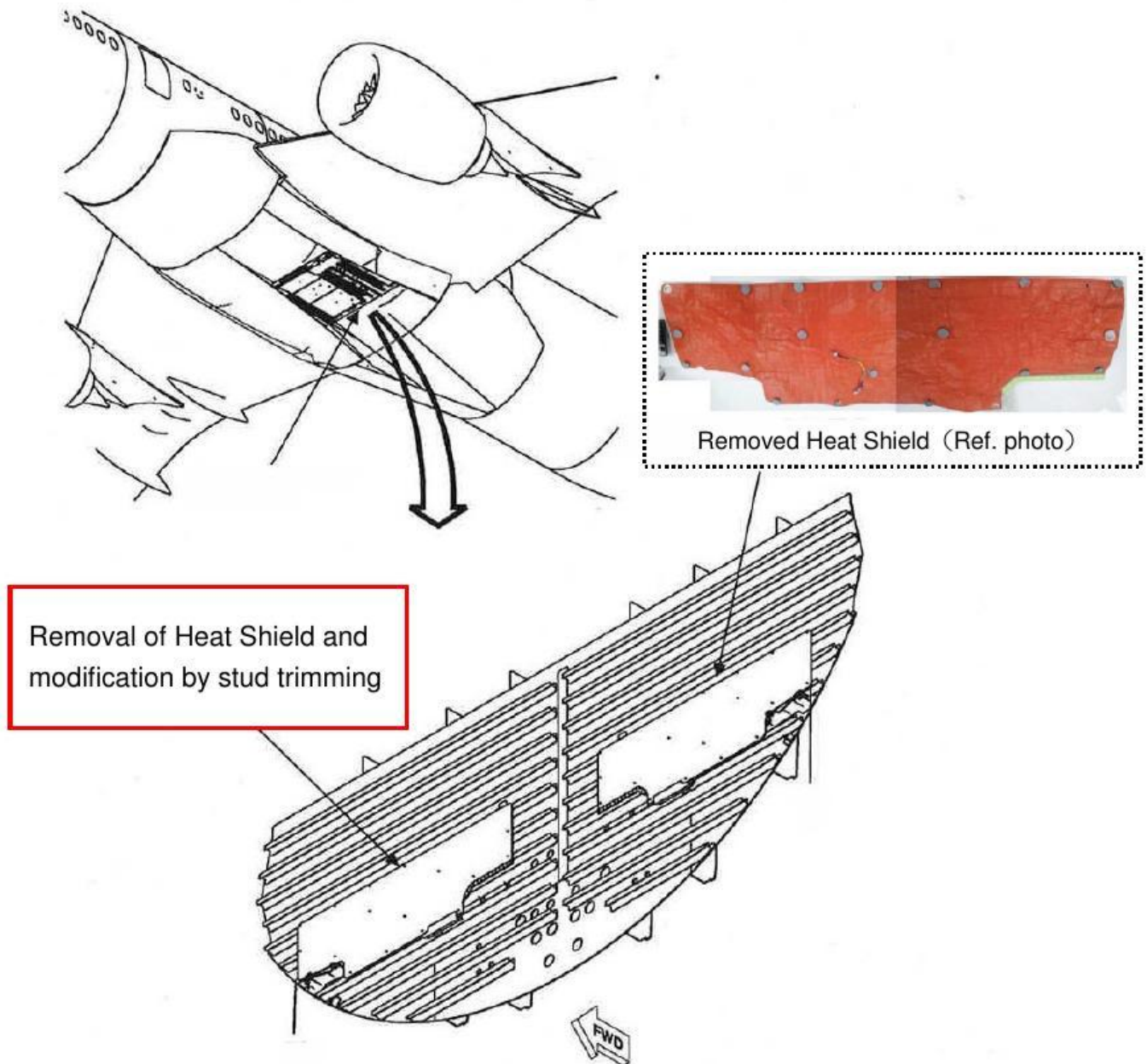
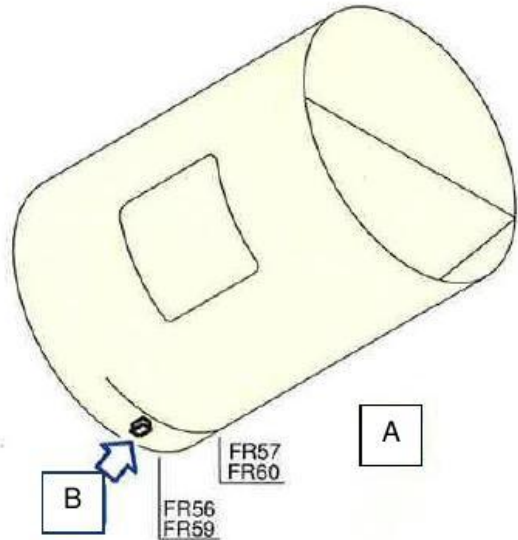
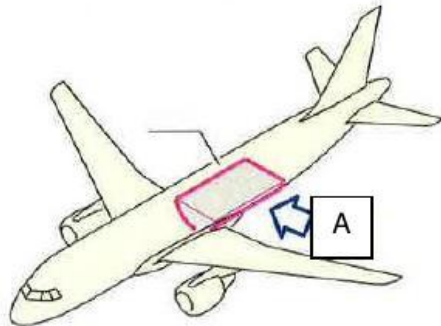

Fig. 1-15

Appendix 2

Airbus's examples of the inspection and modification
(including design change) for PDA prevention

Model	Title
A320	DOORS – CARGO COMPT DOOR HYD SYSTEM – IMPROVE LOCKING AND INTERFACE TOLERANCE OF MANUAL SELECTOR VALVE (MSV) LEVER (SB A320-52-1160)



Replace with improved MSV Lever

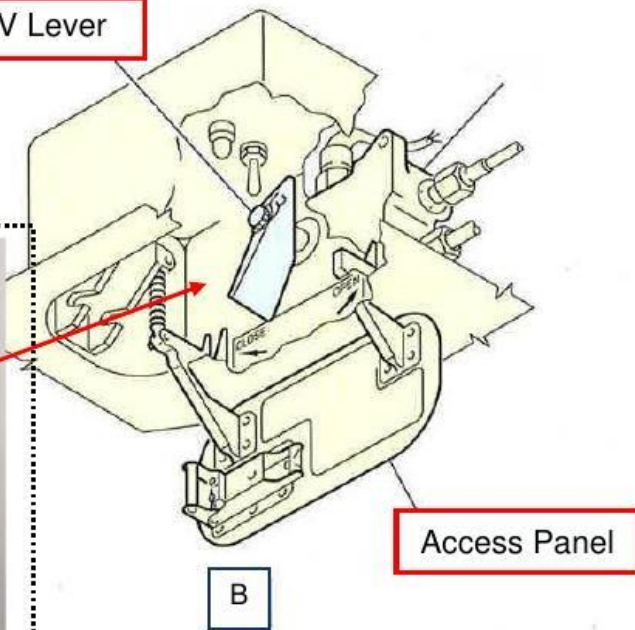
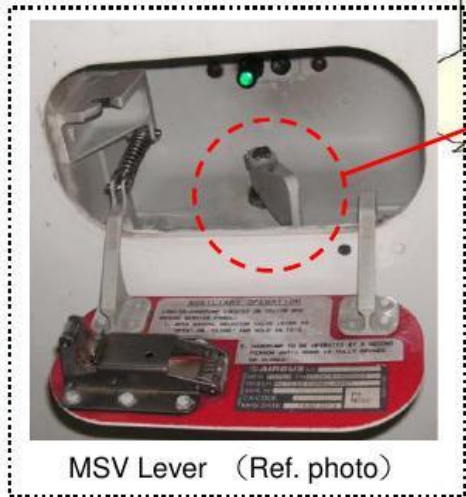

Fig. 2-1

Model	Title
A320	NACELLE & PYLON – AFT MOVABLE FAIRING – RIB 5 RE-DESIGN (SB A320-54-1028)

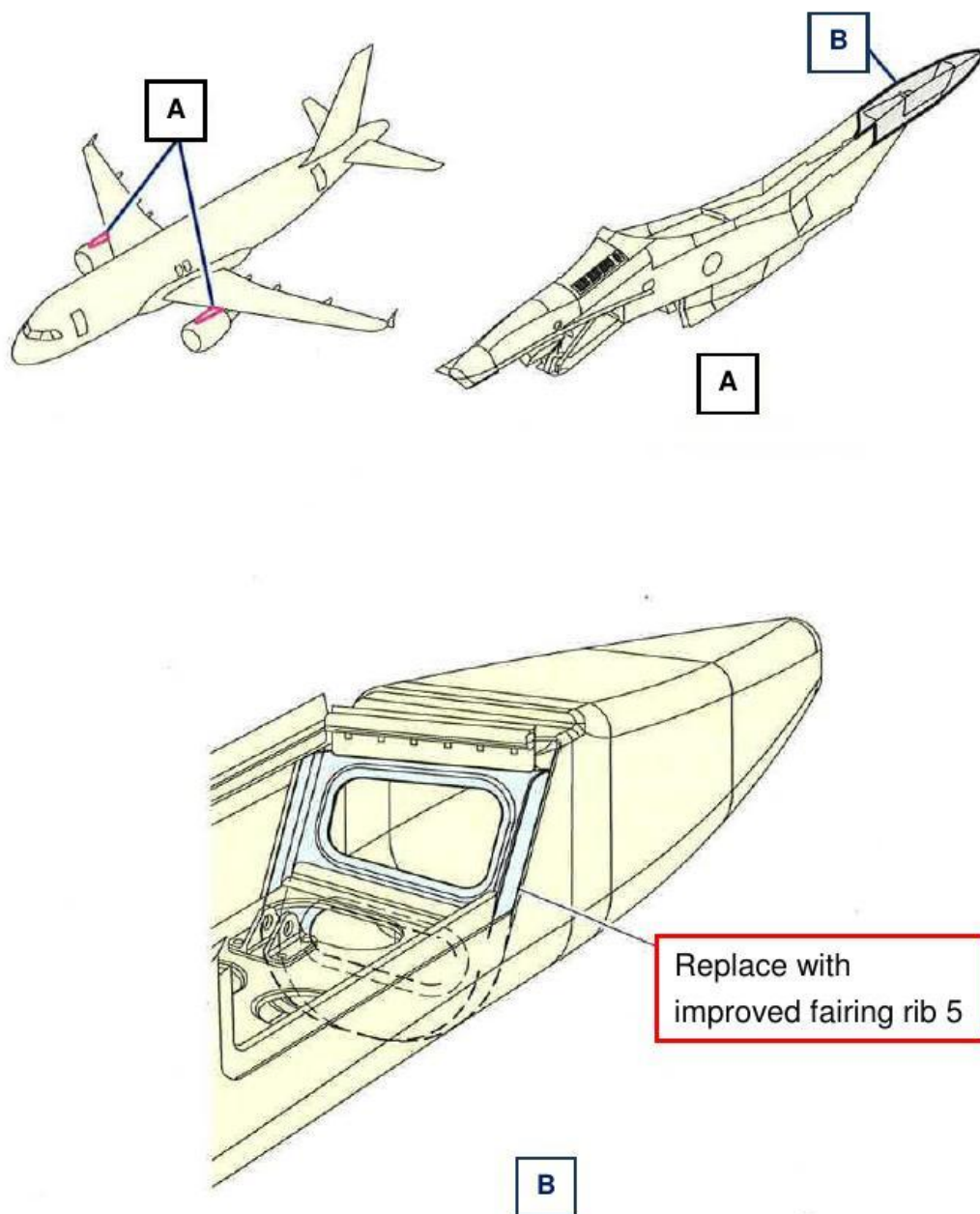

Fig. 2-2

Model	Title
A320	STABILIZERS - RUDDER SIDE SHELL SANDWICH REPAIR INSPECTION (SB A320-55-1041)

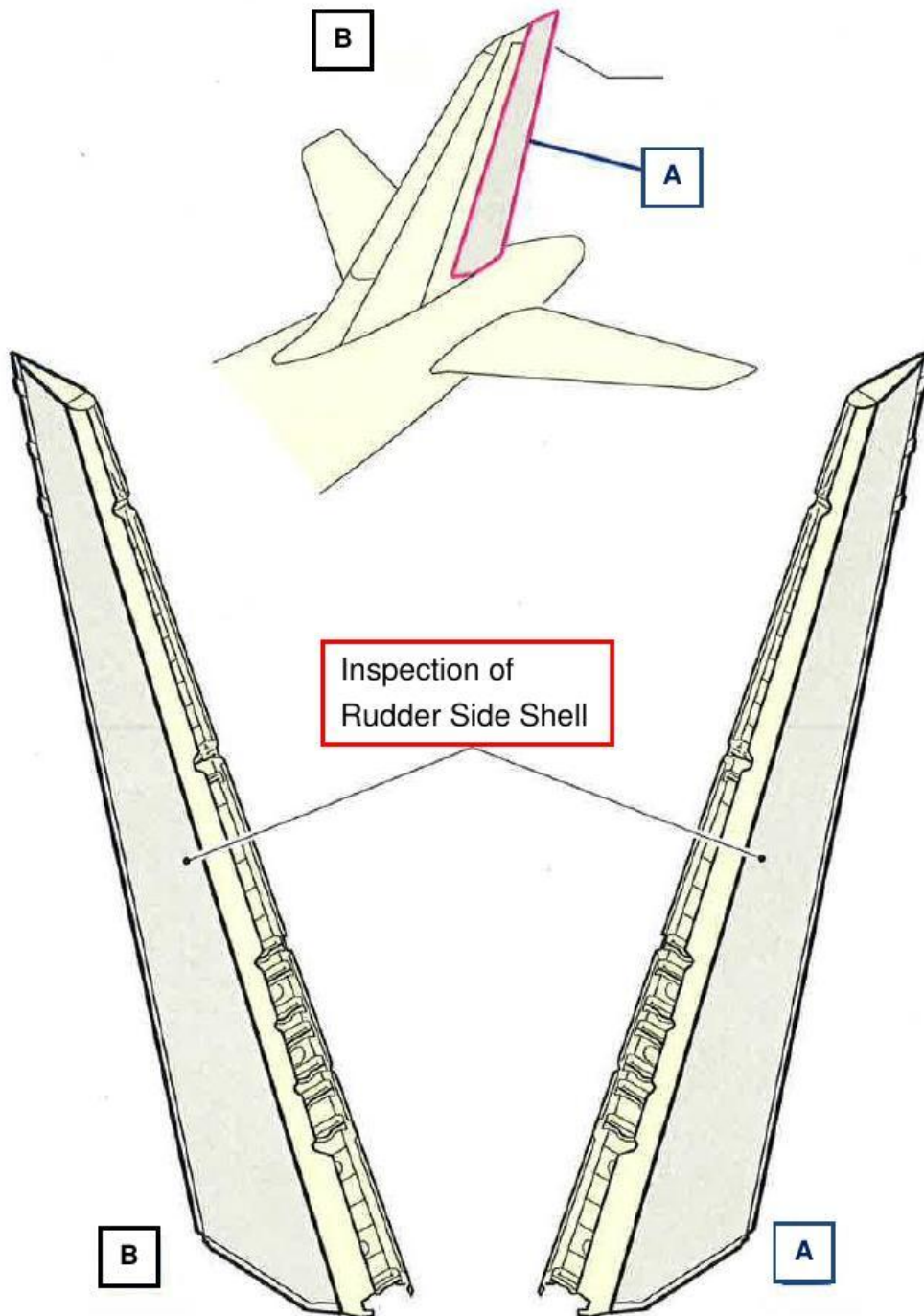

Fig. 2-3

Model	Title
A320	POWER PLANT - FAN COWL DOORS - INTRODUCE AN IMPROVED OIL FILLER DOOR LATCH DESIGN ON IAE ENGINE (SB A320-71-1061)

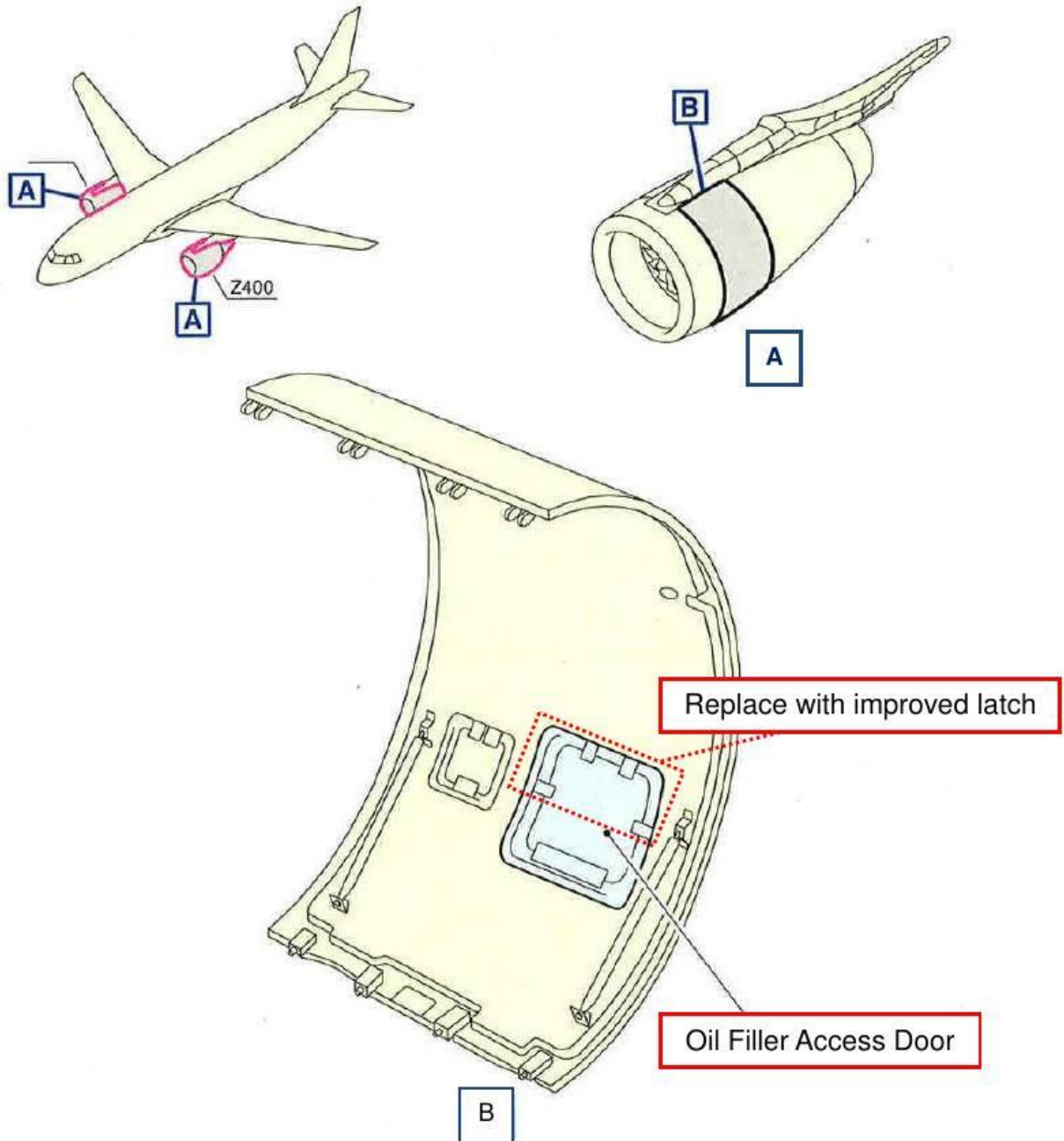

Fig. 2-4

Model	Title
A320	APPLY SHL TECHNOLOGY ON LANDING LIGHTS (TFU33.42.00.004)

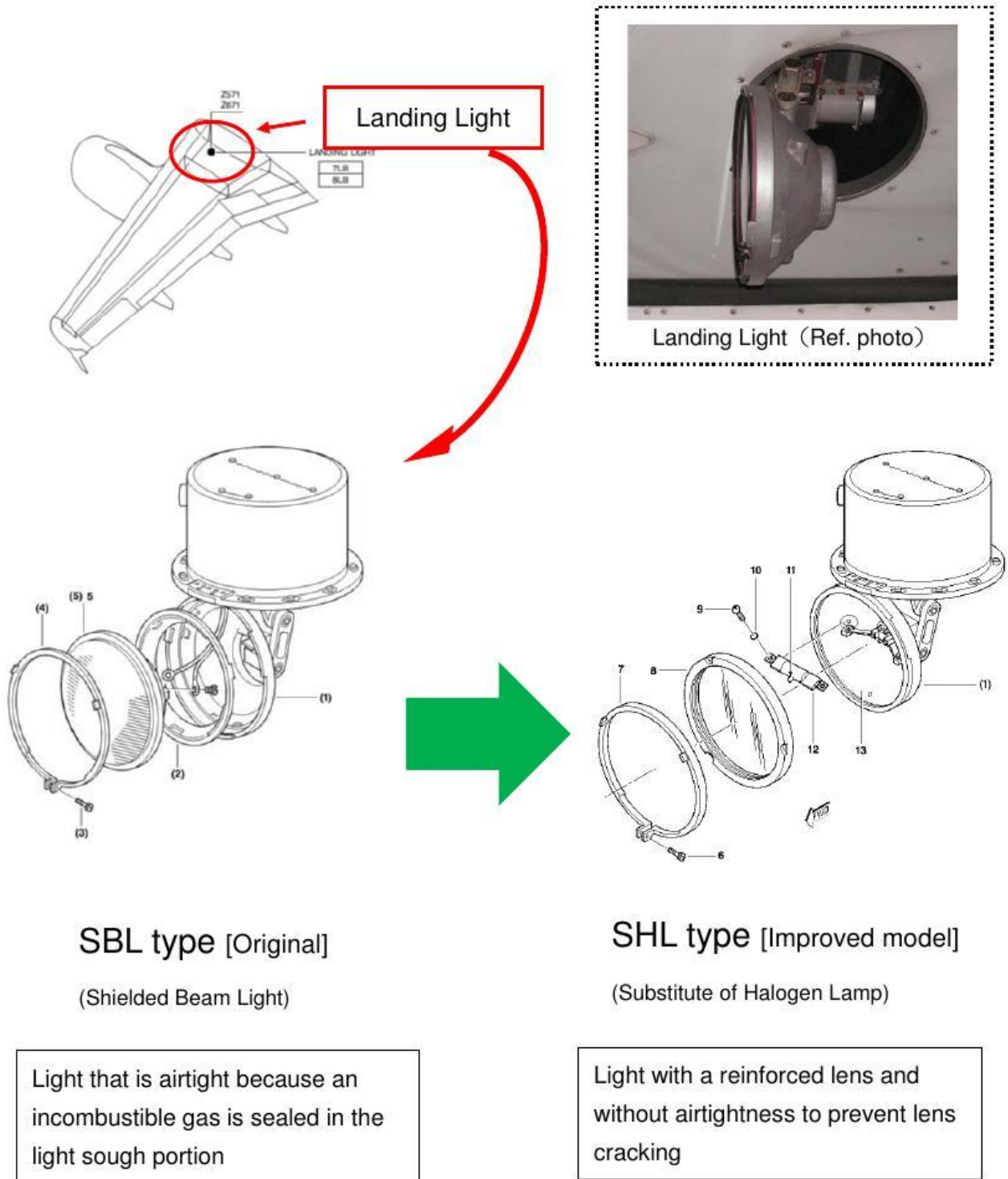

Fig. 2-5

Model	Title
A330	FUSELAGE – REAR FUSELAGE – RELOCATE VHF 2 ANTENNA (SB A330-53-3112)

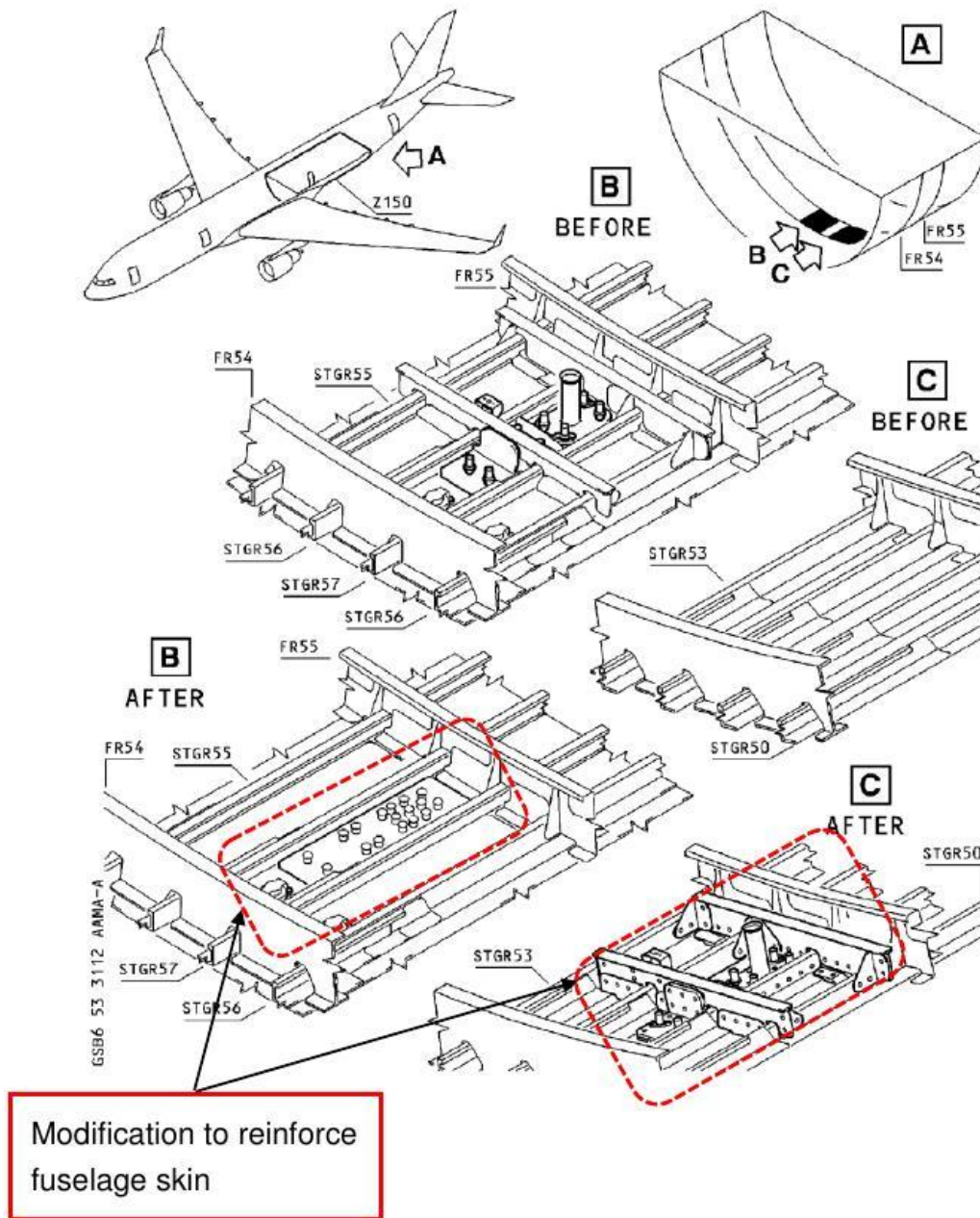

Fig. 2-6

Model	Title
A330	DOORS – SERVICE DOORS – IMPROVE SERVICE PANEL ACCESS DOORS IN SECTION 16 AND 18 (SB A330-52-3108)

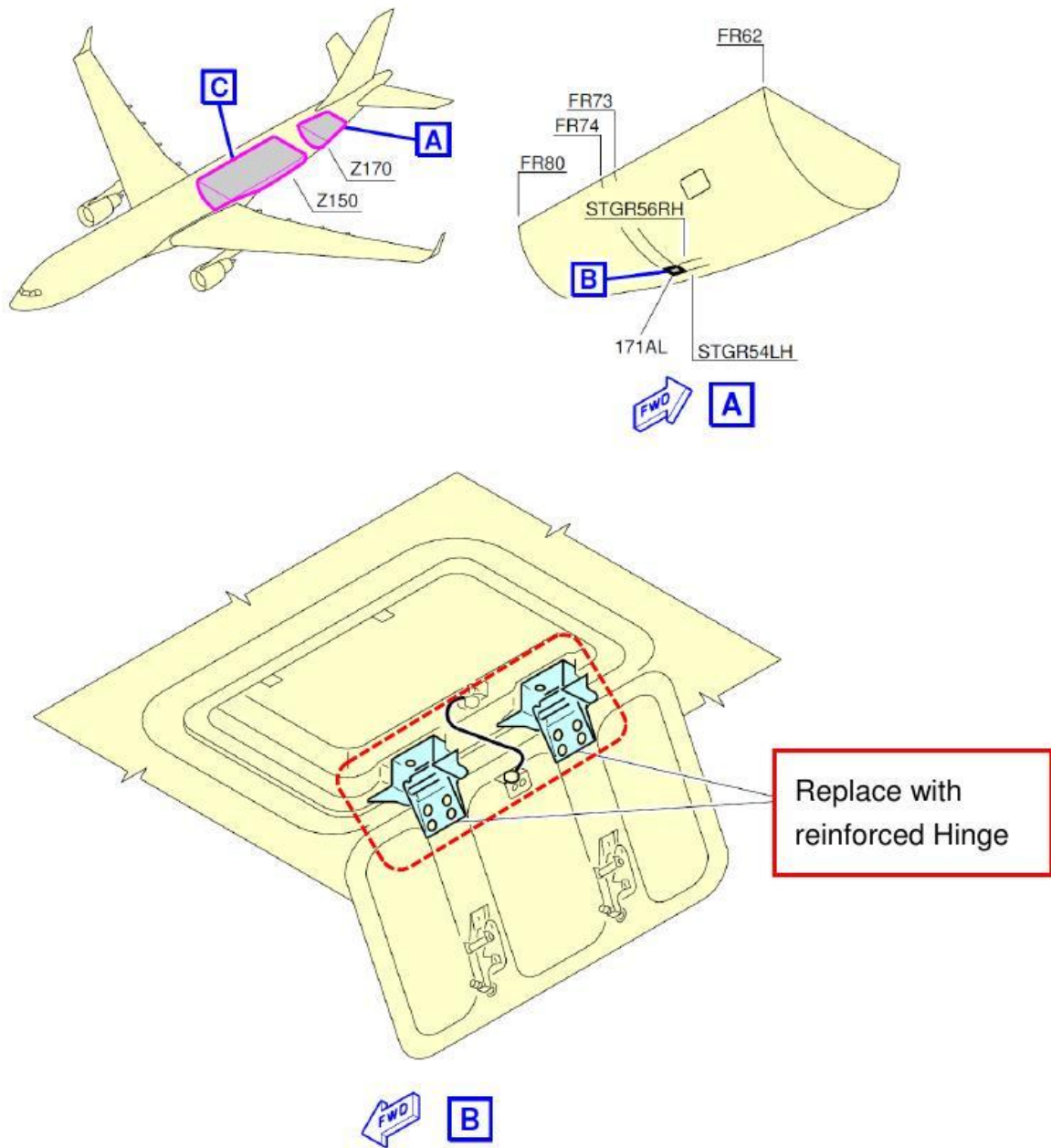

Fig. 2-7

Model	Title
A330	DOORS - SERVICE DOORS-MODIFICATION OF LATCHING MECHANISM OF POTABLE WATER SERVICE PANEL (SB A330-52-3086)

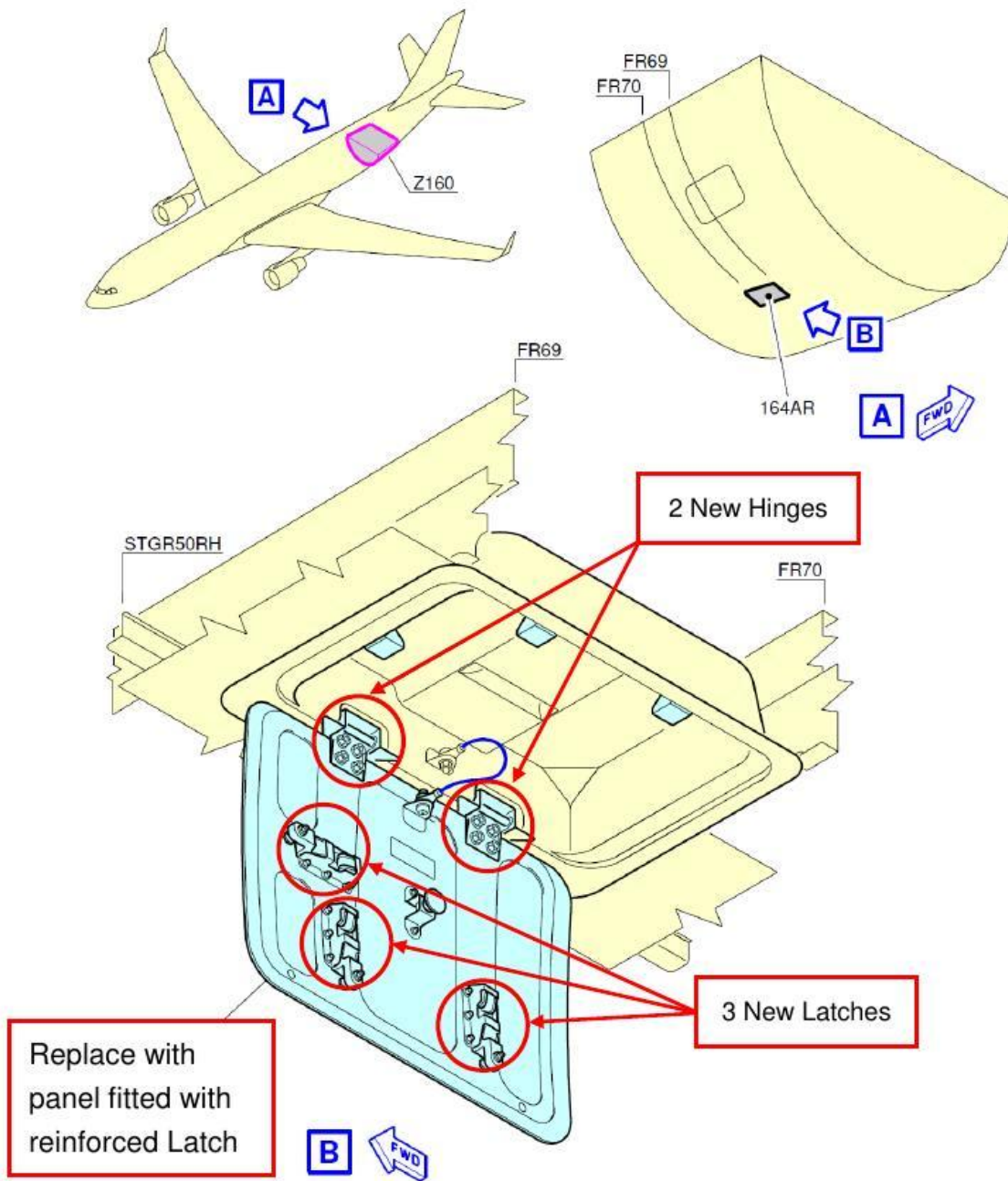

Fig. 2-8

Appendix 3

Calling attention using posters summarizing past PDA events

- (1) Boeing 737 (B737)
- (2) Boeing 767 (B767)
- (3) Boeing 777 (B777)
- (4) Boeing 787 (B787)
- (5) Airbus A320 (A320)
- (6) Bombardier DHC-8-400 (Q400)

737-800 Prevent PDA! Detect signs of PDA quickly!

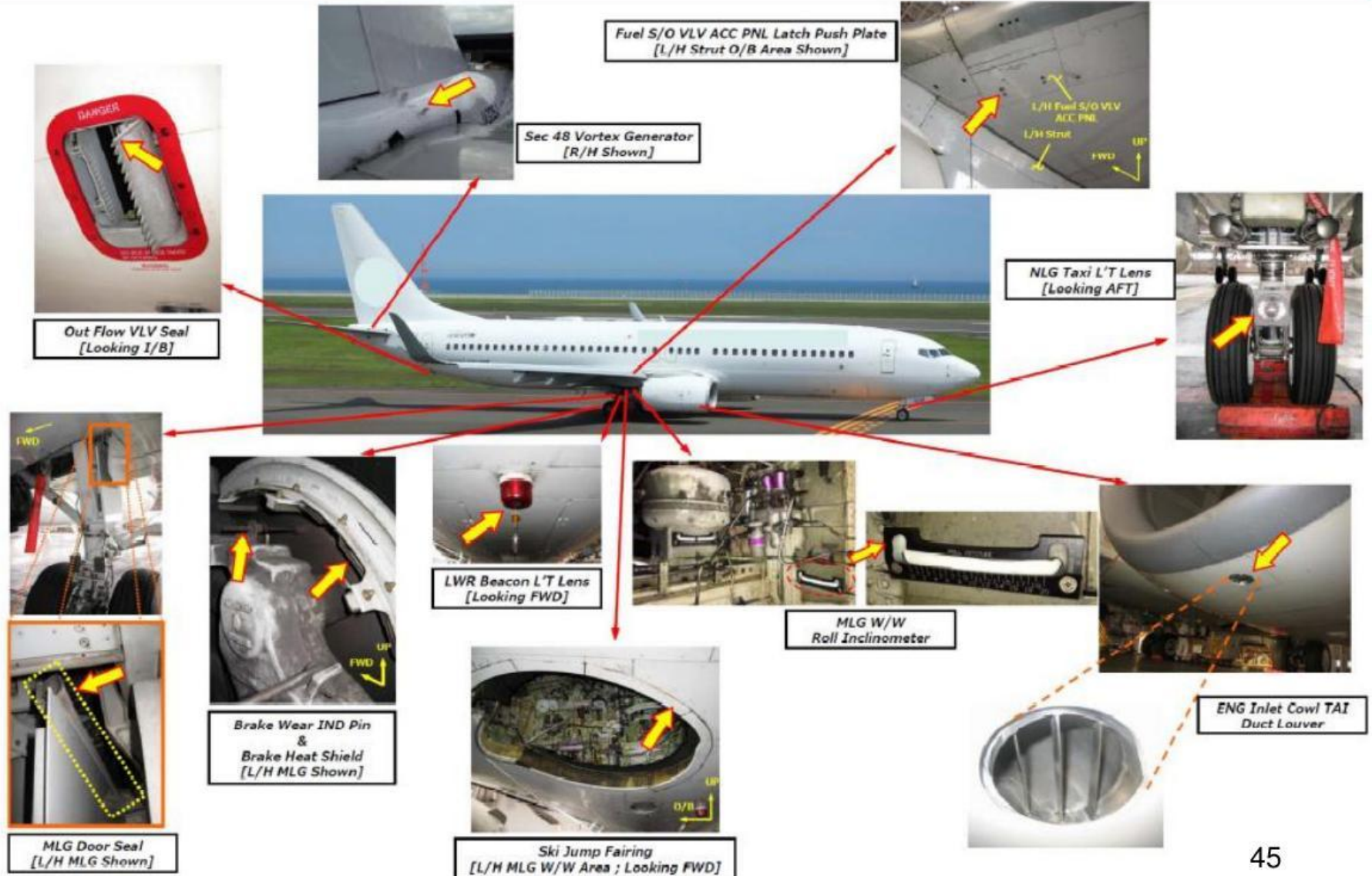

767 Prevent PDA! Detect signs of PDA quickly!



777 Prevent PDA! Detect signs of PDA quickly!

MLG Uplock Spring
[L/H MLG W/W; Looking FWD]

Wing TE LWR Blade Seal
[O/B Flap I/B Area, R-Wing Shown]

I/B Slat
Main & AUX Track Skirt Fairing
[#7 Slat I/B LWR Area Shown]

(GE ENG)
ENG Fan OGV Faring Panel
[FWD looking AFT]

LDG L'T & Taxi L'T Lens
[Looking AFT]

Tail Strobe LT Lens
[Looking Up]

ENG FWD Center Body Skin
[Looking O/B]

MLG Drag & Side Brace Downlock Spring
[L/H MLG Shown; Looking FWD]

Flaperon I/B & O/B Seal
[L/H Flaperon O/B Seal Shown]

MLG Junction Box Spacer
[Looking AFT]

MLG Drag Strut Door
[L/H Shown]

787 Prevent PDA! Detect signs of PDA quickly!

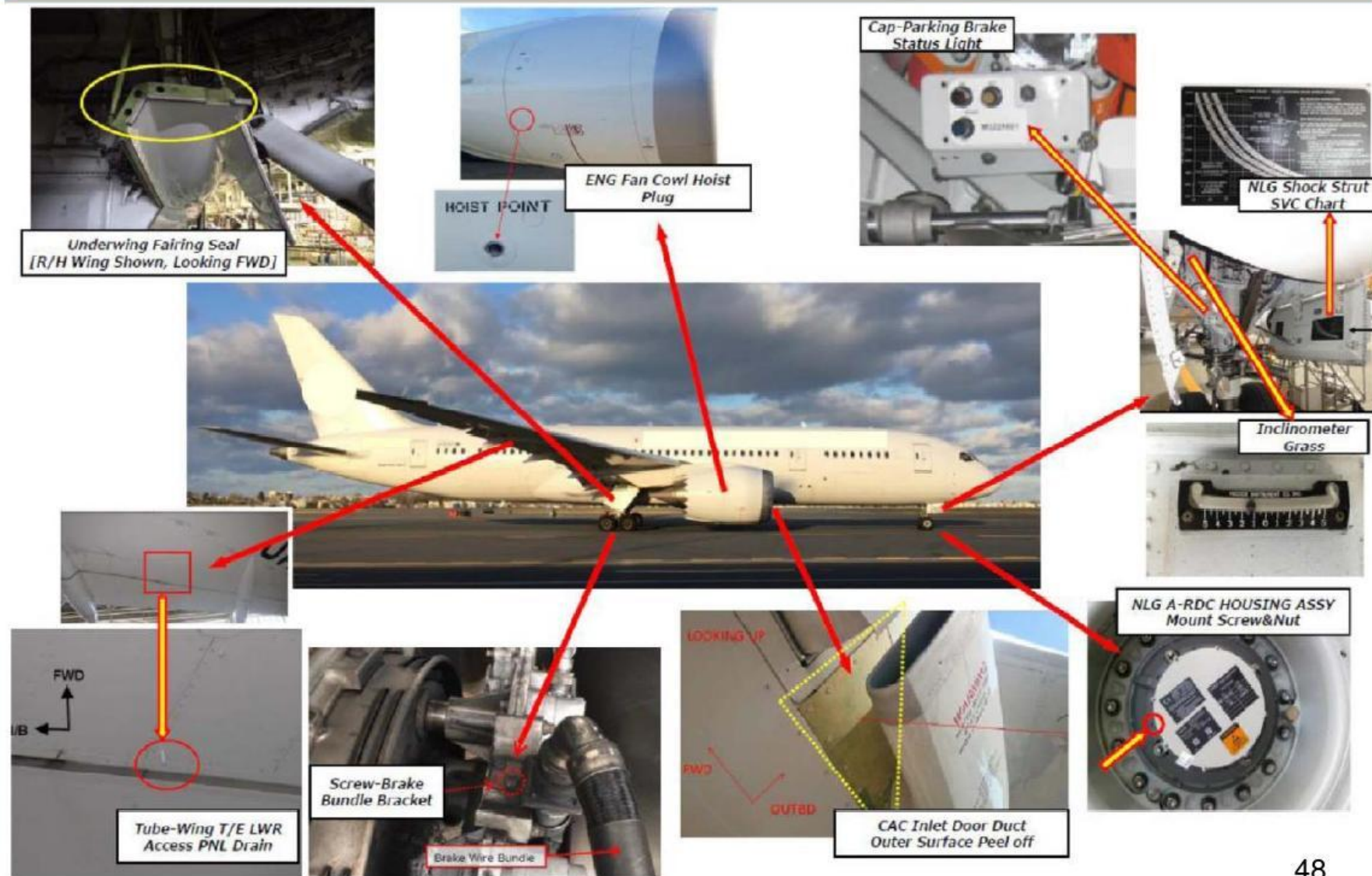

A320

Prevent PDA! Detect signs of PDA quickly!

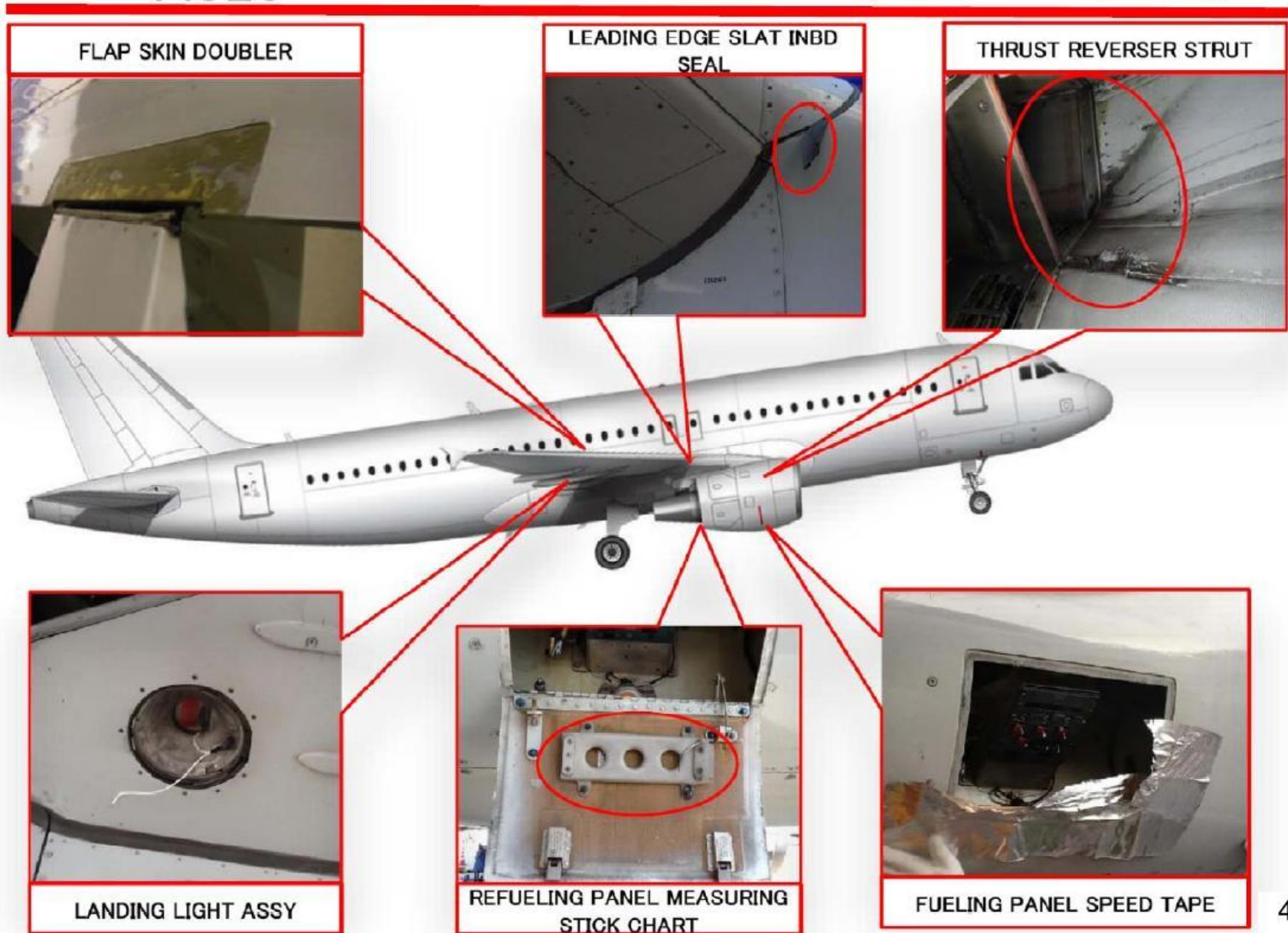

Q400

Prevent PDA! Detect signs of PDA quickly!

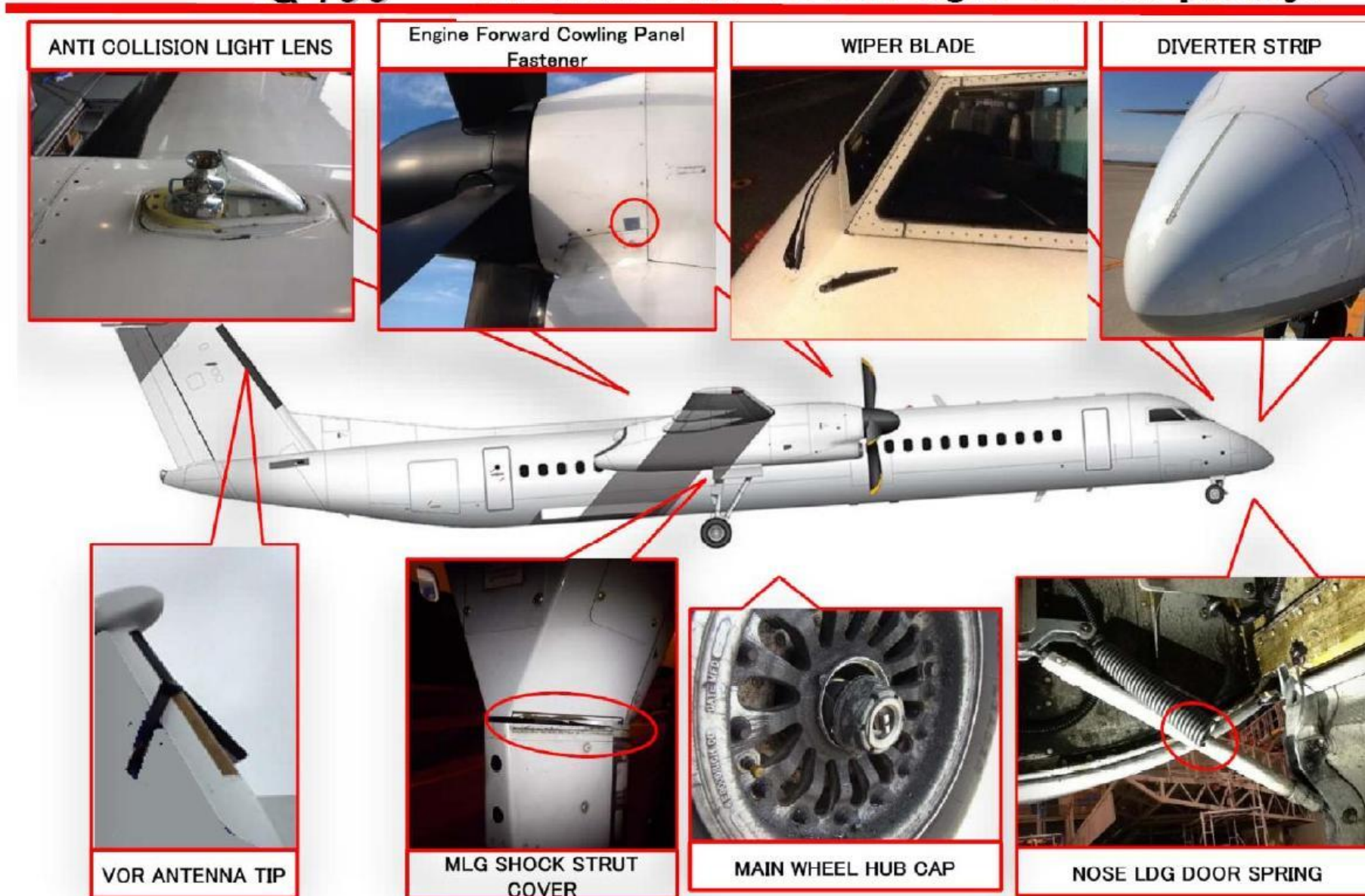

Use by non-aviation personnel strictly prohibited.